

# Optimizing the turning radius of a vehicle using symmetric four wheel steering system

V. Arvind

**Abstract**— The main objective of this project is to decrease the turning radius of the vehicle using four wheels symmetric steering system (4WS). The system being analyzed here is a mechanical linkage between the front and the rear axle with a rack and pinion steering system at both the ends. This mechanical system is studied by kinematic analysis of the steering system geometry and the turning radius is calculated for a vehicle with and without this four wheel symmetric steering. These measurements are compared to know the effect of the system on the vehicle in terms of the turning radius.

**Index Terms**— Symmetric four wheel steering system, Turning radius optimization.

## 1 INTRODUCTION

It is very hard for a medium size sedan to take a U-turn on a busy road with the little space available for the vehicle to actually make the turn. It is also hard for the driver to take the vehicle a little backward and then make the turn as the roads are busy and small. In such a case, if the vehicle is equipped with four wheel steering system, it will be easy for the driver to actually make the turn with ease even in the small space that is available for him. But the main thing is that we have two configurations in four wheel steering systems called same phase and opposite phase. In order to reduce the turning radius of the vehicle, we need the opposite phase configuration of four wheel steering system.

The main intension of this paper is to reduce the turning radius of a vehicle as much as practically possible without crossing the practical limits of design and assembly of the components of the steering system. Based on these requirements, a four wheel symmetric steering system is analysed using kinematic approach and a conclusion is drawn regarding the geometry of the optimum steering system and the effect of this on the turning radius of the vehicle. This system is seen not to cross any practical limitations of the vehicle in terms of assembly and spacing. Also the wheels are turned to the optimum extent possible and not exceeding this limit.

## 2 KINEMATIC STEERING

For the kinematic analysis of a steering system, it is important that we know the basic kinematics of the steering. For this the basic steering system is studied.

- Author, V. Arvind is currently pursuing masters degree program in automotive engineering in Amrita Vishwa Vidyapeetham, Coimbatore, India, PH-+91-9500019270. E-mail: vemanarvind@gmail.com

According to Ackerman condition for a front wheel steering system, the difference of the cotangents of the angles of the front outer to the inner wheels should be equal to the ratio of width and length of the vehicle being considered as shown in (1). The terms  $\delta_o$  represents outer wheel angle and  $\delta_i$  represents inner wheel angle. The term  $w$  represents the wheel track and  $l$  represents wheel base.

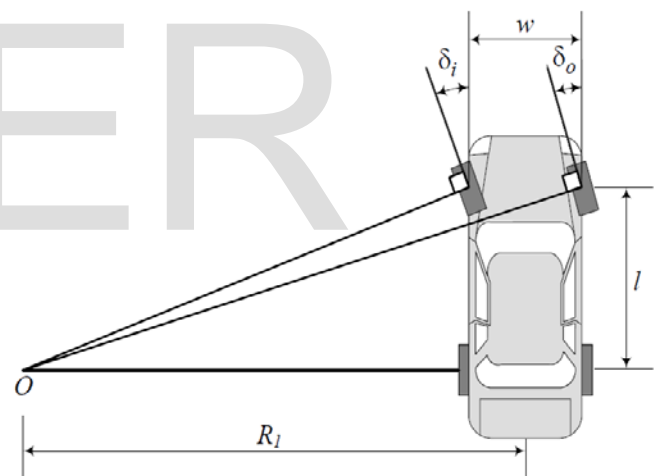

Fig. 1. Kinematic steering illustration

$$\cot\delta_o - \cot\delta_i = \frac{w}{l}(1)$$

## 3 STEERING MECHANISM

The basic and widely used steering mechanism is the rack and pinion mechanism. It is suitable for all types of vehicles with different wheel track and wheel bases. The functioning of this mechanism is also quite simple to understand and use.

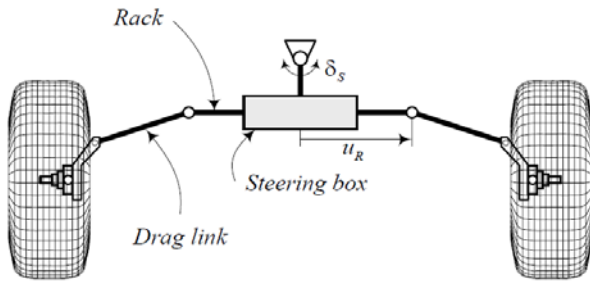

Fig. 2. Rack and pinion steering system

The pinion part of the steering system rotates with the steering wheel operated by the driver. The pinion is a circular gear which meshes with the gears on the rack, which is a longitudinal bar with gear teeth on it. As the pinion rotates, the rotary motion of it is transmitted as longitudinal motion on to the rack. The ends of the rack are usually connected to the kingpins of both wheels at either side by means of a drag link as shown in Fig. 2. This translational motion of the rack pushes or pulls the wheels about their kingpin axis, thus rotating the wheels in the desired direction.

#### 4 TURNING RADIUS

The turning radius of the vehicle is usually measured using the formula as shown in (2) and (3), whose terms are illustrated in the Fig. 3.

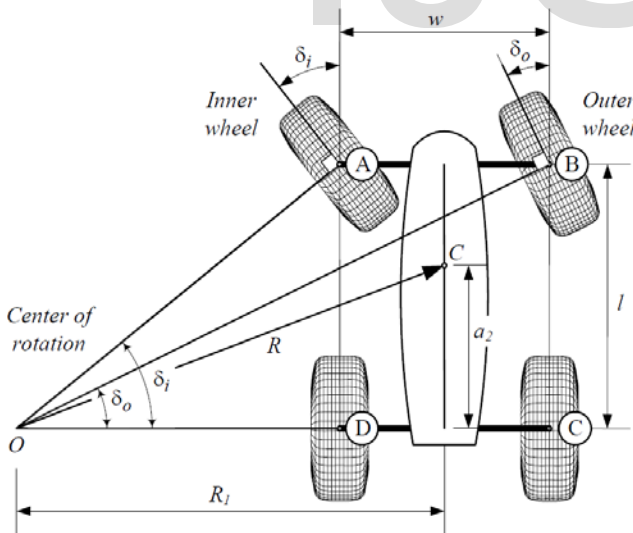

Fig. 3. Turning radius measurement of a vehicle

$$R = \sqrt{a_2^2 + l^2 \cot^2 \delta} \quad (2)$$

$$\cot \delta = (\cot \delta_o + \cot \delta_i) / 2 \quad (3)$$

#### 4.1 Equivalent Bicycle Model

The equivalent bicycle model for the above illustrated vehicle is as shown in Fig. 4 and the corresponding formula used to find the turning radius from this bicycle model is as in (4).

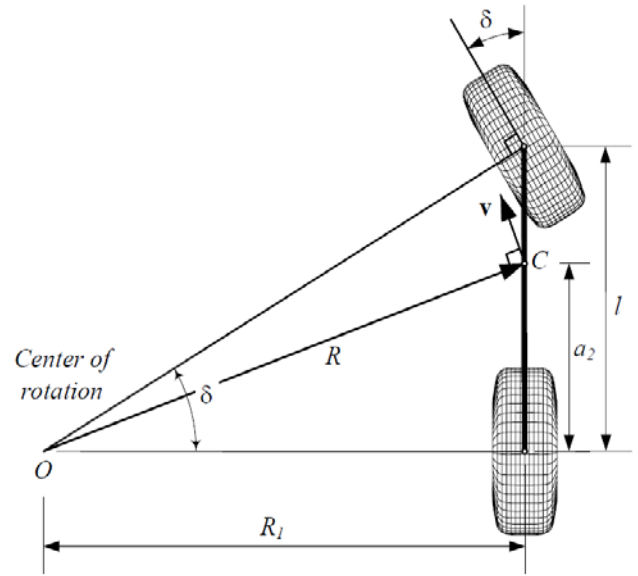

Fig. 4. Bicycle model for measuring turning radius

$$R = \sqrt{a_2^2 + l^2 \cot^2 \delta} \quad (4)$$

#### 4.2 Space Required For Turning

The space required for turning is the space between the two circles in which the whole vehicle fits without going out of the circle. The formula used for measuring this is as shown in (5), (6), (7) and the terms in the formula are illustrated in the Fig. 5.

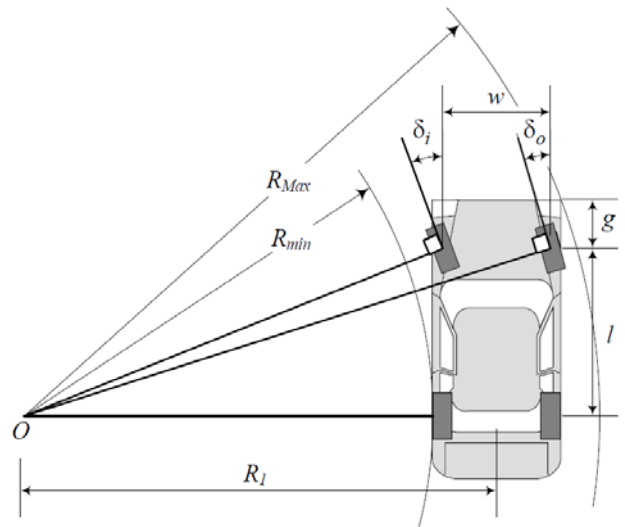

Fig. 5. Space required for turning diagram

$$\Delta R = R_{\text{Max}} - R_{\text{min}} \quad (5)$$

$$R_{\text{Max}} = \sqrt{(R_{\text{min}} + w)^2 + (l + g)^2} \quad (6)$$

$$R_{\text{min}} = R_1 - (w/2) = (l/\tan\delta_i) = (l/\tan\delta_o) - w \quad (7)$$

### 5 FOUR WHEEL STEERING TYPES

There are two types of four wheel steering configurations. The one in which both the front and the rear wheels turn in the same direction is called positive four wheel steering system and the one in which they turn in opposite to each other is called negative four wheel steering system.

#### 5.1 Positive Four Wheel Steering System

The condition for positive four wheel steering system is as given in (8) and the system is as shown in the Fig. 6.

$$\cot\delta_{of} - \cot\delta_{if} = \frac{w_f}{l} - \frac{w_r \cot\delta_{of} - \cot\delta_{if}}{l \cot\delta_{or} - \cot\delta_{ir}} \quad (8)$$

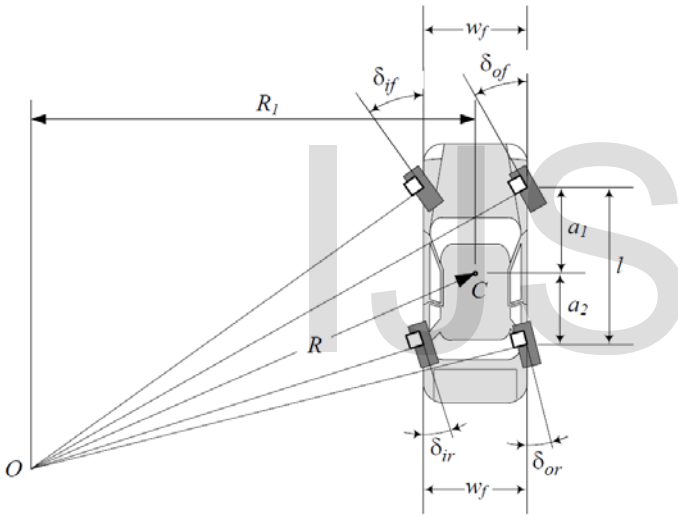

Fig. 6. Positive four wheel steering system

The equations for the positive four wheel steering system are derived from the following equations in (9) and are illustrated in the Fig. 7.

$$\begin{aligned} \tan\delta_{if} &= \frac{c_1}{R_1 - (w_f/2)} \\ \tan\delta_{of} &= \frac{c_1}{R_1 + (w_f/2)} \\ \tan\delta_{ir} &= \frac{c_2}{R_1 - (w_r/2)} \\ \tan\delta_{or} &= \frac{c_2}{R_1 + (w_r/2)} \end{aligned} \quad (9)$$

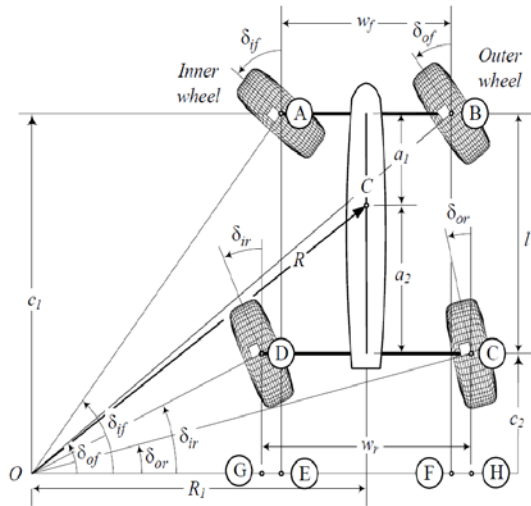

Fig. 7. Positive four wheel steering system angles

$$\cot\delta_{of} - \cot\delta_{if} = w_f/c_1 \quad (10)$$

$$\cot\delta_{or} - \cot\delta_{ir} = w_r/c_2 \quad (11)$$

$$c_1 - c_2 = l \quad (12)$$

$$\frac{w_f}{\cot\delta_{of} - \cot\delta_{if}} - \frac{w_r}{\cot\delta_{or} - \cot\delta_{ir}} = l \quad (13)$$

The turning radius for this system is derived from the bicycle model as shown in the Fig. 8.

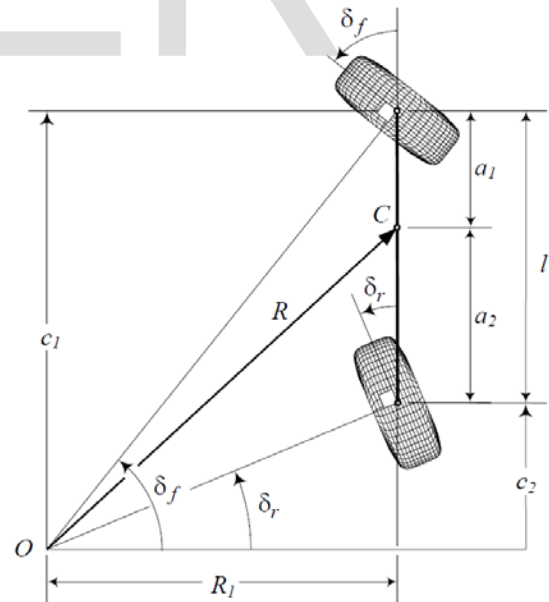

Fig. 8. Bicycle model for positive four wheel steering system

$$R = \sqrt{(a_2 + c_2)^2 + c_1^2 \cot^2 \delta_f} \quad (14)$$

### 5.2 Negative Four Wheel Steering System

The condition for negative four wheel steering system is as given in (15) and the system is as shown in the Fig. 9.

$$\cot\delta_{of} - \cot\delta_{if} = \frac{w_f}{l} - \frac{w_r}{l} \frac{\cot\delta_{of} - \cot\delta_{if}}{\cot\delta_{or} - \cot\delta_{ir}} \quad (15)$$

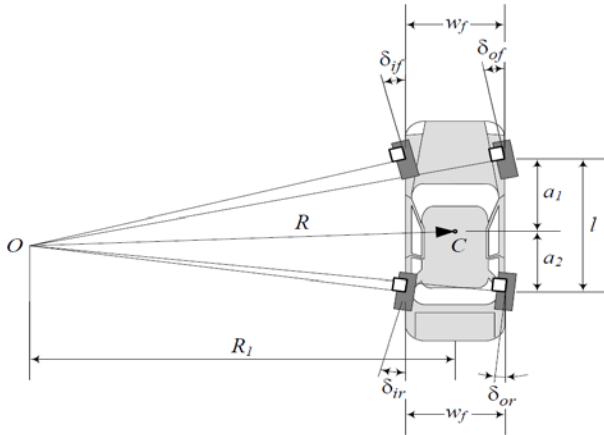

Fig. 9. Negative four wheel steering

The equations for the negative four wheel steering system are derived from the following equations in (16) and are illustrated in the Fig. 10

$$\begin{aligned} \tan\delta_{if} &= \frac{c_1}{R_1 - (w_f/2)} \\ \tan\delta_{of} &= \frac{c_1}{R_1 + (w_f/2)} \\ \tan\delta_{ir} &= \frac{c_2}{R_1 - (w_r/2)} \\ \tan\delta_{or} &= \frac{c_2}{R_1 + (w_r/2)} \end{aligned} \quad (16)$$

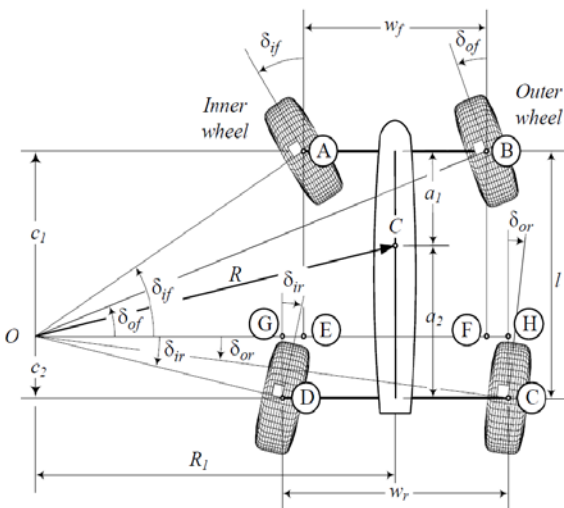

Fig. 10: Negative four wheel steering system angles

$$\cot\delta_{of} - \cot\delta_{if} = w_f/c_1 \quad (17)$$

$$\cot\delta_{or} - \cot\delta_{ir} = w_r/c_2 \quad (18)$$

$$c_1 - c_2 = l \quad (19)$$

$$\frac{w_f}{\cot\delta_{of} - \cot\delta_{if}} - \frac{w_r}{\cot\delta_{or} - \cot\delta_{ir}} = l \quad (20)$$

The turning radius for this system is derived from the bicycle model as shown in the Fig. 11.

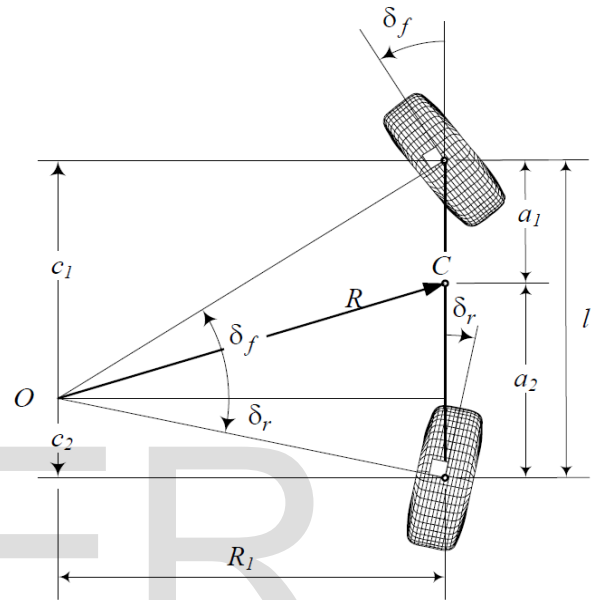

Fig. 11. Bicycle model for negative four wheel steering system

$$R = \sqrt{(a_2 - c_2)^2 + c_1^2 \cot^2 \delta_f} \quad (21)$$

General equation for both four wheel steering systems is given as follows

$$c_1 - c_2 = l \quad (22)$$

$$c_1 = \frac{w_f}{\cot\delta_{of} - \cot\delta_{if}} \quad (23)$$

$$c_2 = \frac{w_r}{\cot\delta_{or} - \cot\delta_{ir}} \quad (24)$$

### 5.3 Symmetric Four Wheel Steering System

A four wheel symmetric steering system will be as shown in the Fig. 12. The main advantage of this system is that the outer and inner front and rear wheels turns to the same angle. This result in the shortest possible turning radius for a vehicle as the lines perpendicular to the wheels meets on the centre line of the wheel base.

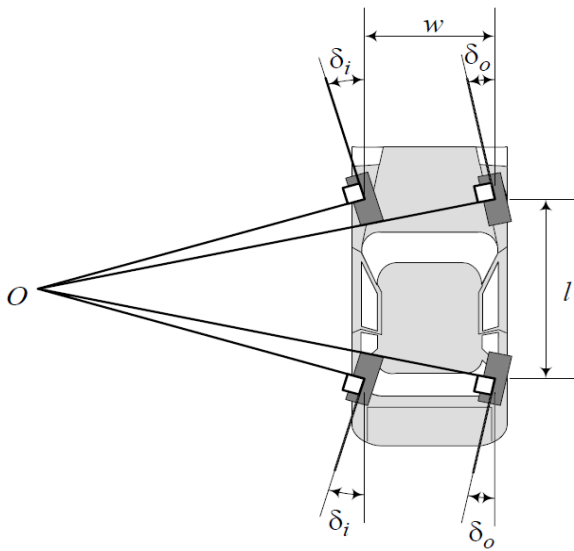

Fig. 12. Symmetric four wheel steering system

### 6 TURNING CIRCLE MEASUREMENT

As per Indian Standards 12222, the turning circle is measured by drawing a circle as shown in Fig. 13 on which the outer most wheel moves when the steering wheel is turned to the maximum lock and the vehicle moving at a speed below 5km/h. This measurement is done on both the sides of the steering wheel lock and the average of these two circles diameter is represented as the turning circle diameter and half of this value is termed as the turning radius of the circle.

If we add 2a to the diameter of the turning circle measured, it gives the space required for the vehicle to make the turn without hitting any obstacle on the way. This is usually measured only as a representation of the total vehicle turning circle rather than the path followed by the wheel.

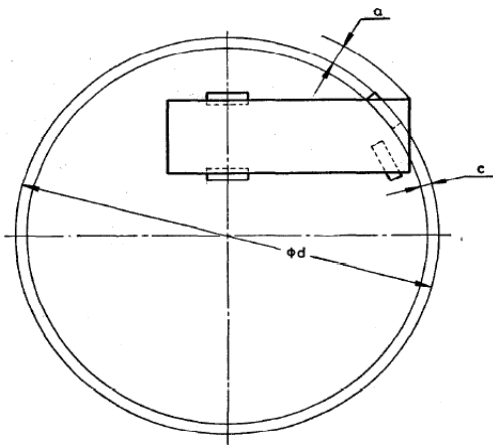

Fig. 13: Turning Circle Measurement

### 7 CASE STUDY 1 – ALTO 800

A case study on the steered wheel angles of a passenger vehicle is done to find the usefulness of the symmetric four wheel steering system in reducing the turning radius of the vehicle compared to its counterpart i.e. the normal front wheel steering system in which only the front wheels are steered.

The data of the vehicle considered are as follows

- Wheel Base : 2360mm
- Wheel Track : 1300mm (approx.)
- Turning radius : 4.6m
- Weight (GVW) : 1140kg

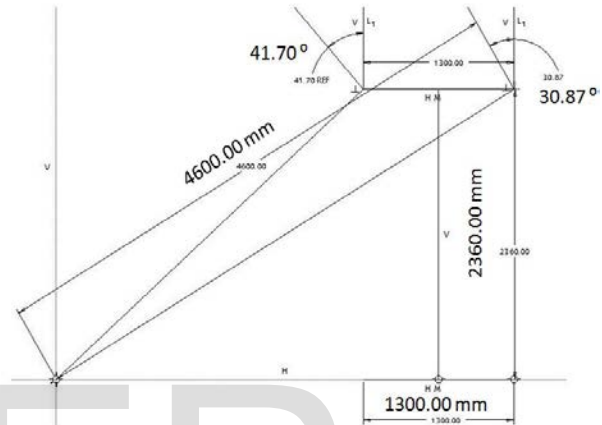

Fig. 14. Steered front wheel angles measurement

Initially only the front wheel steering is considered to find out the angles of the front two wheels at the given turning radius value in the car brochure considering the vehicle wheel base and track values.

Now, keeping one of the angles constant and applying four wheel symmetric steering to this vehicle and measuring the other wheel angle for symmetric four wheel steering geometry, we get the following as the resultant turning radius using this system.

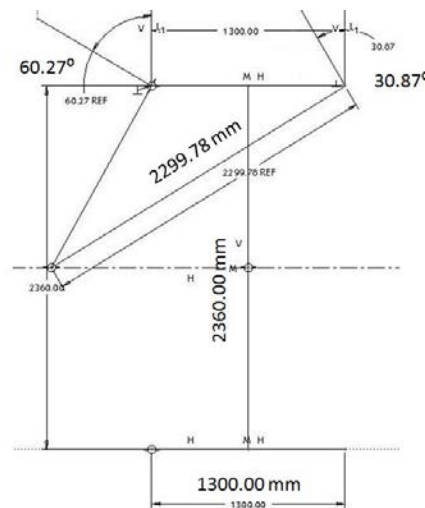

Fig. 15. Modified steering wheels angles 1

Now, keeping the other angle constant and applying four wheel symmetric steering to this vehicle and measuring the other wheel angle for symmetric four wheel steering geometry, we get the following as the resultant turning radius using this system.

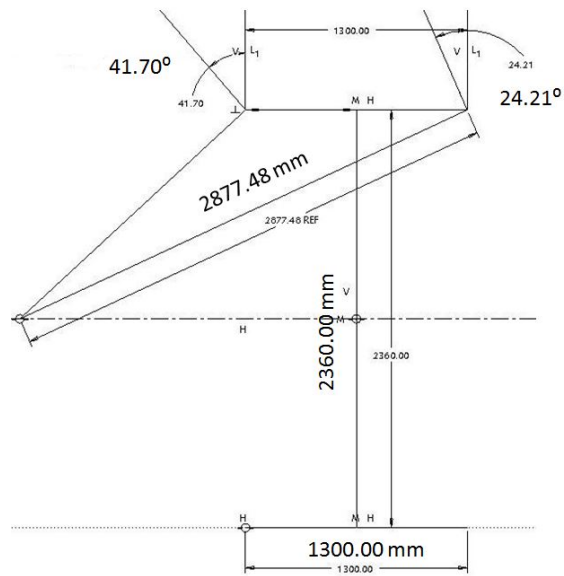

Fig. 16. Modified steering wheels angles 2

Out of the two observations, it is evident that the second system gives the optimum turning radius without exceeding the practical limitations of the vehicle which is the turning of the inner wheel to an angle of  $60.27^\circ$  to one extreme.

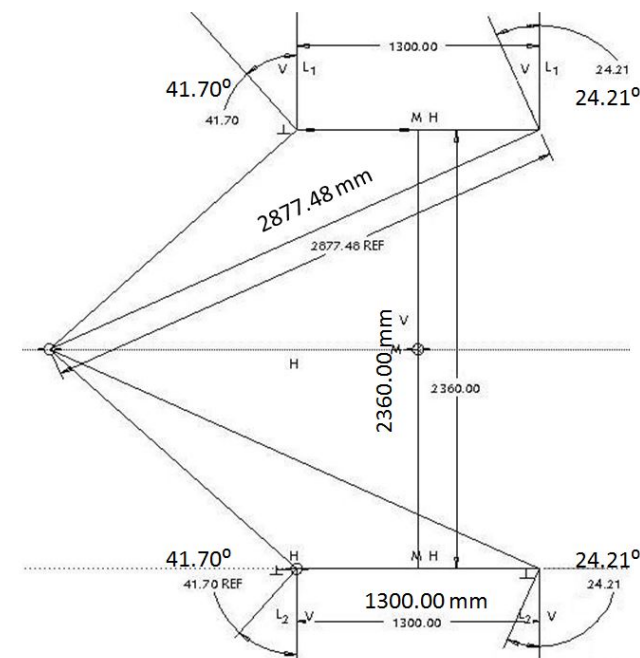

Fig. 17. Optimum symmetric four wheel steering

Fig. 17 shows the optimum steering wheel angles practically suitable for a vehicle to reduce the turning radius of the vehicle. This optimum configuration gives 37% reduction of the turning radius for this vehicle.

### 8 CASE STUDY 2 – FORD FIGO

Another case study on the steered wheel angles of a passenger vehicle is done to find the usefulness of the symmetric four wheel steering system in reducing the turning radius of the vehicle compared to its counterpart i.e. the normal front wheel steering system in which only the front wheels are steered.

The data of the vehicle considered are as follows

- Wheel Base : 2500mm (approx.)
- Wheel Track : 1500mm (approx.)
- Turning radius : 4.9m
- Weight (GVW) : 1500kg (approx.)

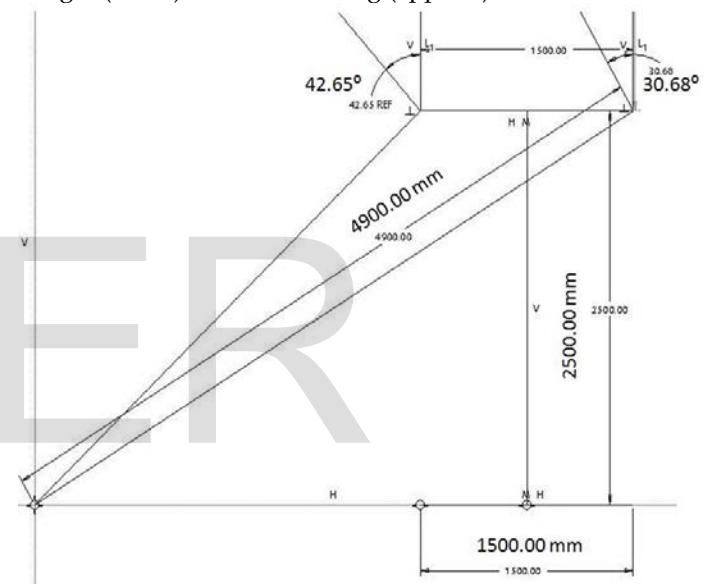

Fig. 18. Steered front wheel angles measurement

Initially only the front wheel steering is considered to find out the angles of the front two wheels at the given turning radius value in the car brochure considering the vehicle wheel base and track values.

Now, keeping one of the angles constant and applying four wheel symmetric steering to this vehicle and measuring the other wheel angle for symmetric four wheel steering geometry, we get the following as the resultant turning radius using this system.

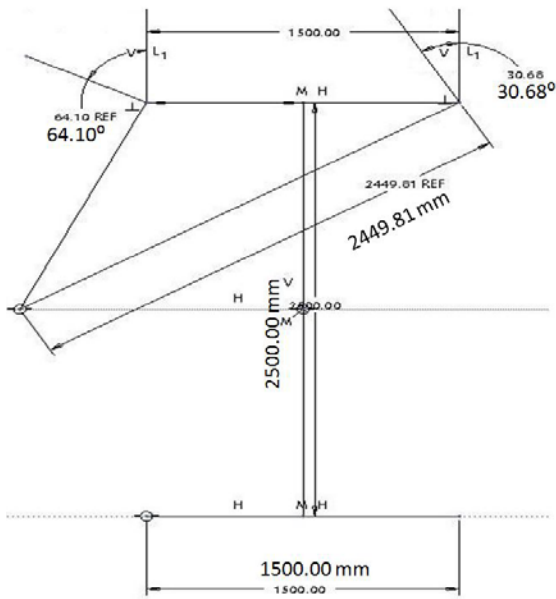

Fig. 19. Modified steering wheels angles 1

Now, keeping the other angle constant and applying four wheel symmetric steering to this vehicle and measuring the other wheel angle for symmetric four wheel steering geometry, we get the following as the resultant turning radius using this system.

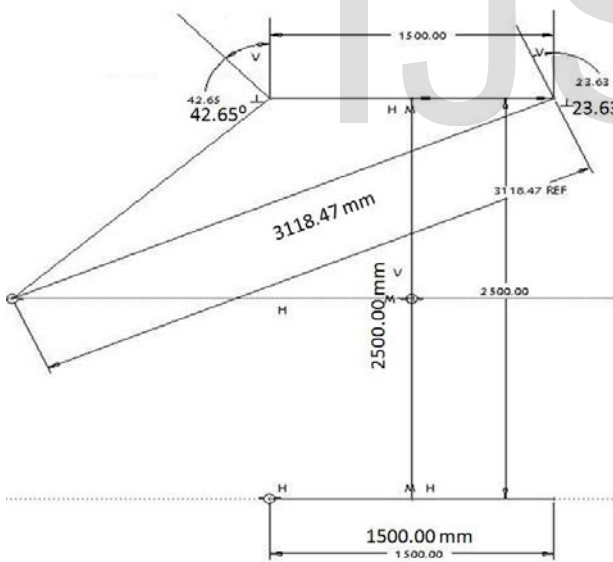

Fig. 20. Modified steering wheels angles 2

Out of the two observations, it is evident that the second system gives the optimum turning radius without exceeding the practical limitations of the vehicle which is the turning of the inner wheel to an angle of 64.10° to one extreme.

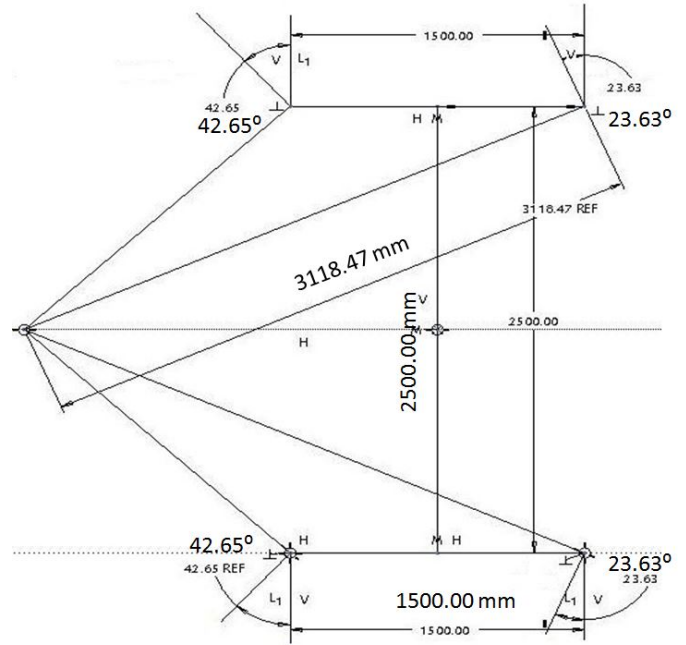

Fig. 21. Optimum symmetric four wheel steering

Fig. 21 shows the optimum steering wheel angles practically suitable for a vehicle to reduce the turning radius of the vehicle. This optimum configuration gives 36% reduction of the turning radius for this vehicle.

## 9 ACKERMANN LINKAGE ARRANGEMENT

The Ackermann linkage arrangement for front wheel steering system will be as shown in the Fig. 22.

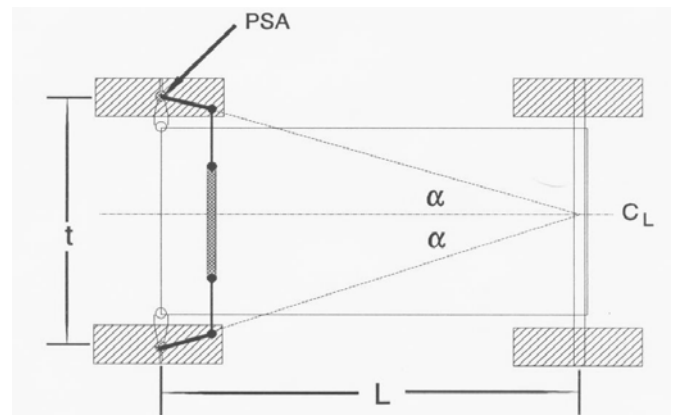

Fig. 22. Ackermann linkage arrangement for front wheel steering system

### 9.1 For symmetric four wheel steering system

The Ackermann linkage arrangement for symmetric four wheel steering system will be as shown in the Fig. 23

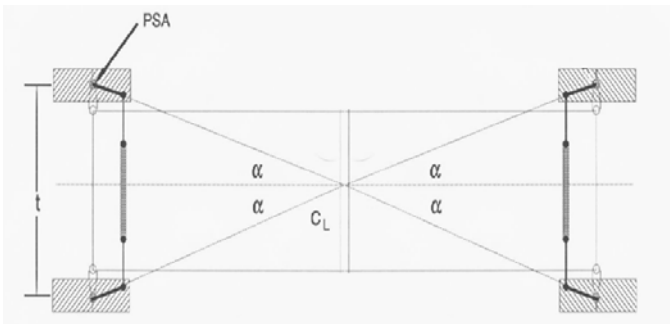

Fig. 23. Ackermann linkage for symmetric four wheel steering system

The present symmetric four wheel steering system should have the linkages in such a way as shown in the figure so as to have perfect steering of all the four wheels when steered.

## CONCLUSION

From the kinematic analysis it is evident that the turning radius of the vehicle can be reduced up to 35% by using four wheel symmetric steering system without crossing the practical limitations.

## ACKNOWLEDGMENT

I would like to thank my guide P. Nantha Kumar sir for guiding me in doing this project and my class advisor and chairperson of Mechanical Engineering Department Dr. S. Thirumalini madam for the support given in all the possible ways in completing this work. I also thank all my family members and friends for their support and help.

## REFERENCES

- [1] Reza N. Jazar *Vehicle Dynamics: Theory and Applications* Springer 2008
- [2] Indian Standards - 12222
- [3] L. Pascali, P. Gabrielli and G. Caviasso, Improving Vehicle Handling and Comfort Performance Using 4WS, SAE Paper No. 2003-01-0961
- [4] ALTO 800 Car Brochure
- [5] Ford Figo Car Brochure