

# Design of a Bank Vault Security System with Password, Thermal & Physical Interrupt Alarm

Sayemul Islam, Md. Saiduzzaman

**Abstract**— Security is one of the most concerning factor in bank vault system. Without proper and strong security a vault can be penetrated. Most of the systems are based on human supportive security protocol. The main purpose of this paper is to construct a microcontroller based automated system which can give instant protection against any break-in by hackers or against physical penetration and send warning signal to the law enforcement team immediately. The system consists of a microcontroller associated with passive infrared sensor, shock sensor and keypad with display panel.

**Index Terms**— Passive Infra-Red Sensor (PIR Sensor), Light Dependent Resistor (LDR), ATmega328 (high-performance Atmel 8-bit AVR RISC-based microcontroller), PIC16F690, Arduino Uno, Proteus, MaxMSP.

## 1 INTRODUCTION

Bank companies often have many of their branches rented in the commercial buildings with floors above or under them occupied by other companies or individuals which may or may not have effective security system installed. So there is always a chance for the intruders to break into that floor and getting access to the bank by simply cutting hole in the floor or ceiling. The system described in this paper does not only secure the vault when the bank is empty but also secure the access when the bank is fully functional. It is cheap, easy to install and maintenance. The power consumption is very low; the system doesn't need any operator once it is installed so in the long run the system is very economic and ideal for any organization who wants full proof effective security system.

The system has 4 protection layers. The full system consists of a motherboard which contains the micro controller, keypad interface, display interface, motor controller interface with H-bridge circuitry, some input interface from the sensors. PIRs (Passive Infra-Red sensors) are used for thermal movement detection & LDR (Light Dependent Resistor) sensors are used to detect unauthorized door movement. Each PIR can cover 10m-45m at an angle of  $\pm 15$  degrees. So the number of PIR sensors can be increased under the condition for protection of larger area. This project is entirely based on the microcontroller to ensure unbreakable system. The micro controller is code protected so that no one except the vendor / owner can override the system by changing password or anything

else. Here two microcontrollers are used, one is ATmega328 & another is PIC16F690. The first one was used to interface the keypad & a 16x2 LCD display, also get input from the PIR & LDR sensors. The second one was used to drive the H-bridge for the operation of the automatic vault door.

## 2 METHODOLOGY

As it has been said before, it has 3 steps security layer, first of all is password protection. A pre-programmed password can be saved & modified if necessary by the user, only authorized persons will know the password. After pressing the password on the keyboard, if the password is accepted, the door will open & will disable all the alarm systems. If the password is not accepted it will ring a warning sound & alert the user. If wrong password is inserted more than 3 times, it will secure the door & alert the law enforcement team.

The second part of the security layer is physical interrupt alarm. A 'Laser' near to the door is aimed at a LDR sensor. If by any chance, anyone cut the bolts of the door or blows it away, the broken particle of the door or the door itself will cut the laser & will trigger the alarm.

The third part of the protection scheme is thermal security system. If anyone plans to get into the vault by breaking the vault floor or wall, the PIR sensor will detect the thermal movement & will alarm the trigger instantly. The second & third part of the protection scheme is only activated when the door is locked & de-activated when the door is unlocked.

## 3 GENERAL DESCRIPTION OF EQUIPMENTS

### 3.1 GENERAL DESCRIPTION FOR ARDUINO

It's an open-source physical computing platform based on a simple microcontroller board consists an ATmega328 micro

- Sayemul Islam has completed Bachelor degree program in Electrical and Electronic Engineering, Dhaka, Bangladesh.  
Email: sayem707@gmail.com
- Md. Saiduzzaman has completed Bachelor degree program in Electrical and Electronic Engineering, Dhaka, Bangladesh.  
Email: sonetshah@yahoo.com

controller, and a development environment for writing software for the board. Arduino can be used to develop interactive objects, taking inputs from a variety of switches or sensors and controlling a variety of lights, motors and other physical outputs. Arduino projects can be stand-alone, or they can be communicating with software running on your computer (e.g. Flash, Processing, Proteus and MaxMSP.). An Arduino board consists of an 8-bit Atmel AVR microcontroller with complementary components to facilitate programming and incorporation into other circuits. An important aspect of the Arduino is the standard way that connectors are exposed, allowing the CPU board to be connected to a variety of interchangeable add-on modules known as shields. Some shields communicate with the Arduino board directly over various pins, but many shields are individually addressable via an I<sup>2</sup>C serial bus, allowing many shields to be stacked and used in parallel. Official Arduinos have used the megaAVR series of chips, specifically the ATmega8, ATmega168, ATmega328, ATmega1280, and ATmega2560. A handful of other processors have been used by Arduino compatibles. Most boards include a 5 volt linear regulator and a 16 MHz crystal oscillator, although some designs such as the LilyPad run at 8 MHz and dispense with the onboard voltage regulator due to specific form-factor restrictions. An Arduino's microcontroller is also pre-programmed with a boot loader that simplifies uploading of programs to the on-chip flash memory, compared with other devices that typically need an external programmer [1], [2]. Arduino Uno is shown in figure 1:

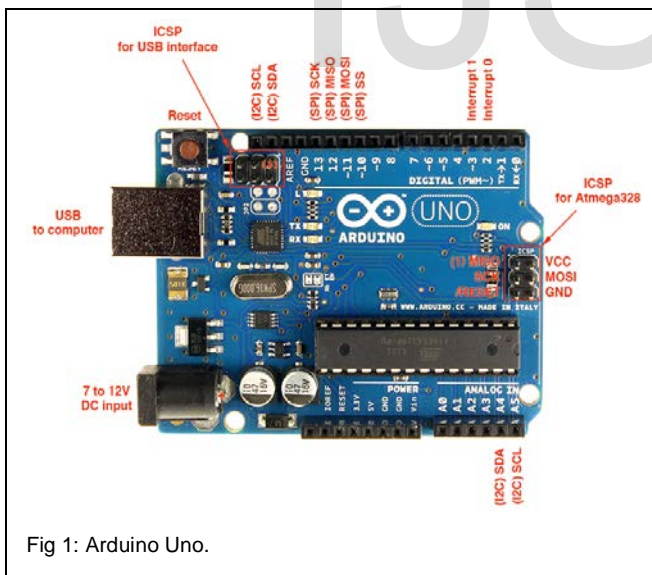

Fig 1: Arduino Uno.

### 3.2 GENERAL DESCRIPTION FOR 4x4 MATRIX KEYPAD

The keypad consists of 16 keys 0-9, \*, # & A to D, it has 4 column line & 4 row lines, that is why it is called 4x4 matrix keypad. The keypad was connected to insert the password in the micro controller by the user to open the vault door. Figure 2 shows a 4x4 matrix keypad:



Fig 2: 4x4 Matrix Keypad

### 3.3 GENERAL DESCRIPTION FOR 16x2 LCD DISPLAY

I've used a LCD display to show the instructions & indications to the user. It is a 2 line 16 Character Display driven by the ATmega328 micro controller. [3]. Figure 3 shows a 16x2 LCD panel.

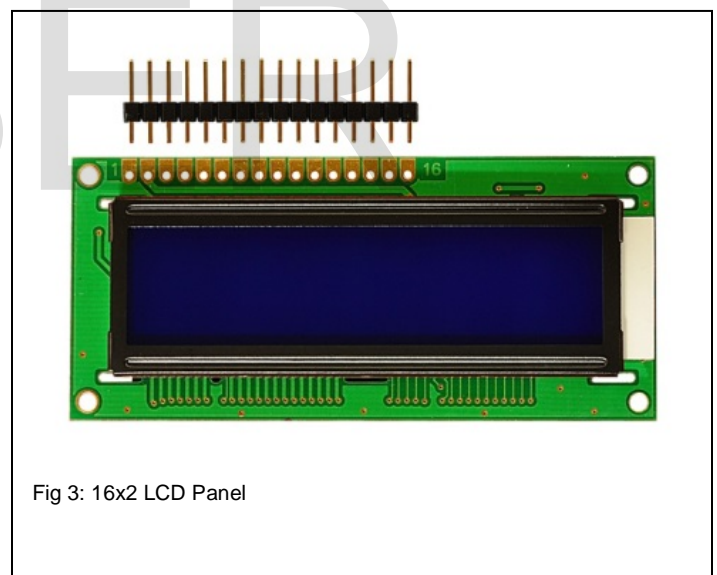

Fig 3: 16x2 LCD Panel

### 3.4 GENERAL DESCRIPTION FOR PASSIVE INFRARED SENSOR:

A Passive Infrared sensor (PIR sensor) is an electronic device that measures infrared (IR) light radiating from objects in its field of view. PIR sensors are often used in the construction of PIR-based motion detectors. Apparent motion is detected when an infrared source with one temperature, such as a human, passes in front of an infrared source with another temperature, such as a wall. This is not to say that the sensor detects the heat from the object passing in front of it but that

the object breaks the field which the sensor has determined as the "normal" state. Any object, even one exactly the same temperature as the surrounding objects will cause the PIR to activate if it moves in the field of the sensors.

All objects above absolute zero emit energy in the form of radiation. Usually infrared radiation is invisible to the human eye but can be detected by electronic devices designed for such a purpose. The term passive in this instance means that the PIR device does not emit an infrared beam but merely passively accepts incoming infrared radiation. "Infra" meaning below our ability to detect it visually, and "Red" because this color represents the lowest energy level that our eyes can sense before it becomes invisible. Thus, infrared means below the energy level of the color red, and applies to many sources of invisible energy. [4]. Figure 4 shows a Passive Infrared Sensor (PIR)

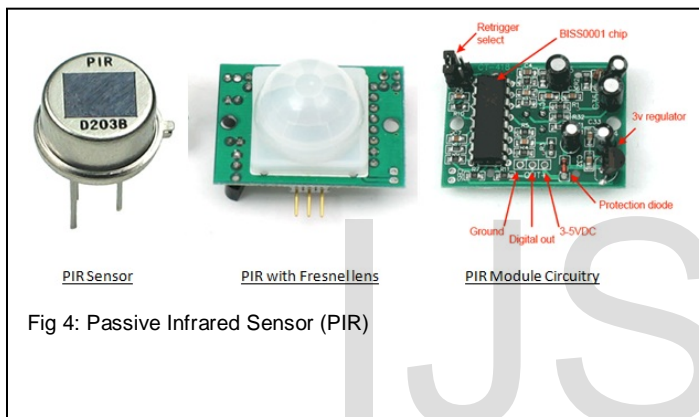

Fig 4: Passive Infrared Sensor (PIR)

### 3.5 GENERAL DESCRIPTION FOR LIGHT DEPENDENT RESISTOR (LDR):

A photo resistor or light dependent resistor is a resistor whose resistance decreases with increasing incident light intensity; in other words, it exhibits photoconductivity.

A photo resistor is made of a high resistance semiconductor. If light falling on the device is of high enough frequency, photons absorbed by the semiconductor give bound electrons enough energy to jump into the conduction band. The resulting free electron (and its hole partner) conduct electricity, thereby lowering resistance.

A photoelectric device can be either intrinsic or extrinsic. An intrinsic semiconductor has its own charge carriers and is not an efficient semiconductor, e.g. silicon. In intrinsic devices the only available electrons are in the valence band, and hence the photon must have enough energy to excite the electron across the entire band gap. Extrinsic devices have impurities, also called dopants, added whose ground state energy is closer to the conduction band; since the electrons do not have as far to jump, lower energy photons (i.e., longer wavelengths and lower frequencies) are sufficient to trigger the device. If a sample of silicon has some of its atoms replaced by phosphorus atoms (impurities), there will be extra electrons available

for conduction. This is an example of an extrinsic semiconductor. Photo resistors are basically photocells. [5]. Figure 4 shows a typical Construction of LDR

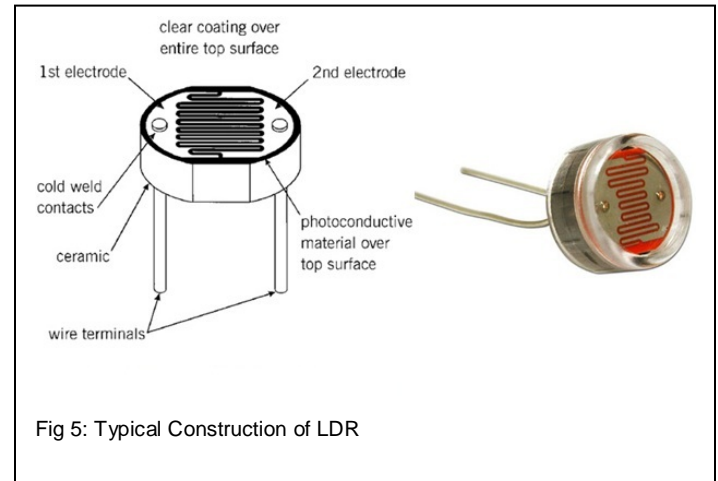

Fig 5: Typical Construction of LDR

### 4 FEATURES OF BANK VAULT SECURITY SYSTEM:

1. Full proof security system.
2. Can be monitored & controlled from distant main office by wireless module.
3. Triple layer security system.
4. Reliable & Durable.
5. Can be used as Home Security System or in Museum as well as Bank Vault.
6. Low power consumption, only 2.4mWatts.
7. No need to keep eye on surveillance continuously.
8. Alert sound & can call law enforcement team if necessary.
9. Battery operated, can be backed up & also mains operated.
10. 24X7 online protection.
11. Heavy duty vault door is controlled by geared motor
12. Auto locking & turning on the Alarm after shutting the vault door.
13. The password can be encrypted & the microcontroller can be code protected.
14. Highly sensitive thermal sensor for burglars.
15. Each PIR sensors can cover 10-45 meters.
16. More PIRs can be connected parallel for larger space.
17. Physical interrupt system for blown door particle & man made interruption.
18. Low cost operating system using Arduino module [ATmega328] in C programming language.
19. Motor driver using PIC16F690 & two high current capacity H-bridge circuits.
20. Overall cost effective & parts are easily available on the market.



### 5 CIRCUIT DIAGRAMS

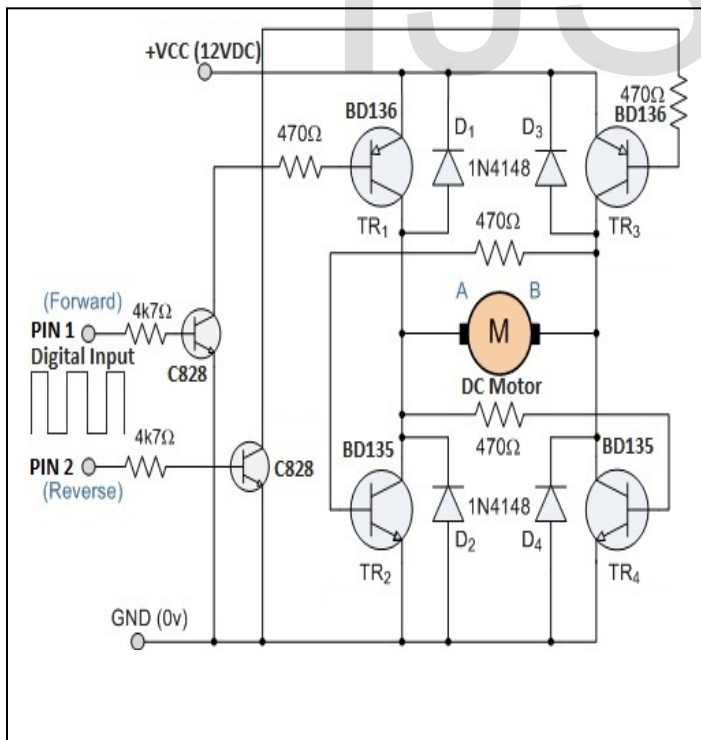
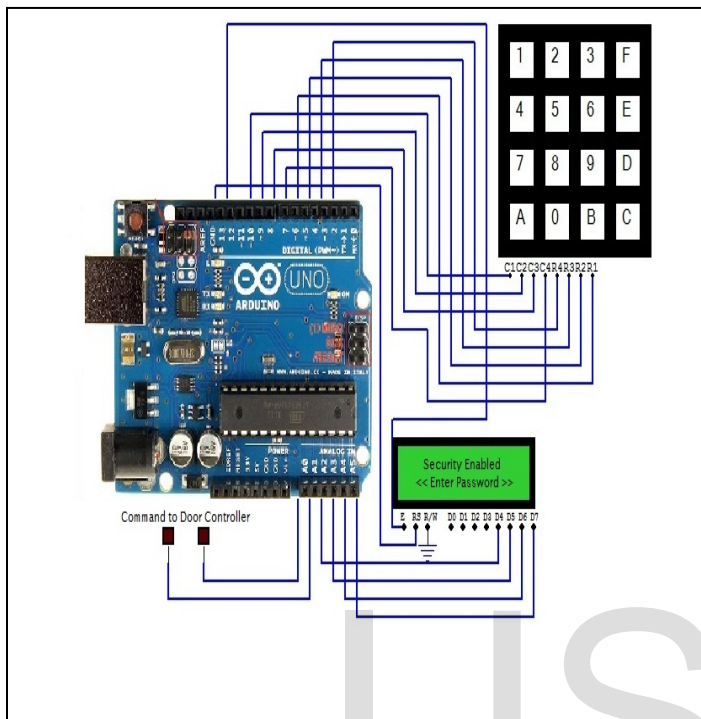

### 6 FLOW CHART FOR THE SYSTEM

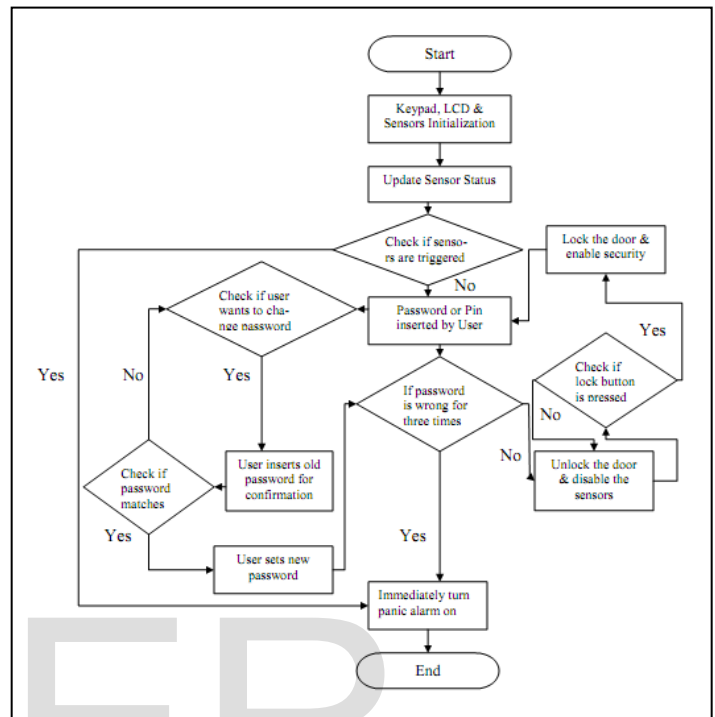

### 7 CONCLUSION

Password security system has been very popular installation among the Bank Vaults, Museum & Expensive houses. This project is not only about the password security but also for thermal & physical interruption alarm, so it has more effectiveness and also it is cheaper technology. Beside that it can be applied to Defense, Museum, shop & House Security System. This protection system will stop thieves, robbers & any kind of intruders & will notify the law enforcement team as soon as possible.

### REFERENCES

- [1] 8-bit AVR Microcontroller, ATMEL, 2011. [Online].
- [2] C. Reas, B. Fry, and J. Maeda, Processing: A Programming Handbook for Visual Designers and Artists. The MIT Press, 2007.
- [3] Jayalakshmi, K., Ramanarayanan, V., "Real-time simulation of electrical machines on FPGA platform", Power Electronics, 2006. IICPE 2006. India International Conference, 19-21 Dec, 2006
- [4] Zhiqiang Zhang, Xuebin Gao, Biswas, J., Jian Kang Wu, "Moving targets detection and localization in passive infrared sensor networks", Information Fusion, 2007 10th International Conference, 9-12 July, 2007
- [5] Wei Chen, Son Tung Nguyen, Coops, R., Oetomo, S.B., "Wireless transmission design for health monitoring at neonatal intensive care units", Applied Sciences in Biomedical and Communication Technologies, 2009. ISABEL 2009. 2nd International Symposium, 24-27 Nov, 2009