

Smart DC Micro-grid for Effective Utilization of Solar Energy

D Ravi Prasad, Dr B.Rajesh Kamath, K.R Jagadisha, S.K Girish

Abstract - This paper deals with the development of a new, smart distributed DC Micro-grid suitable for high-penetration, which efficiently utilizes energy available from distributed, renewable generators is described. This paper deals mainly on solar energy. It is shown that energy saving in excess of 15% is feasible using the proposed DC power distribution system when compared to the current approach where inverters are used. The article also proposes the solar tracking system which improves the power collection efficiency of solar panel by atleast 30%. The proposed DC micro-grid architecture is hybrid in nature and is easily scalable to other power levels. It is ideally suited for residential and commercial applications as well as for powering sustainable communities.

Keywords: DC power distribution, Smart micro-grid, Solar photo-voltaics, LDR, Multi-tap transformer, Microcontroller, Solar tracker.



1. INTRODUCTION

A micro-grid consists of interconnected distributed energy resources capable of providing sufficient and continuous energy to a significant portion of internal load demand. With the strong incentives of green and free energy sources and advancement of battery technology, power generation is not just solely relied on coal-fired or gas-fired power plants but everyone can produce their own electricity from these energy sources to power their own loads to certain power level. Many of these sources and applications are of dc nature but today's electricity infrastructure is still based on ac. Therefore there are **"unnecessary power processing stages to handle the power generation to the user (i.e. dc to ac and back to dc again)"**. In addition, the smart use of power electronics converters can help electricity users lower the generation cost and optimize the system efficiency.

This proposal aims to develop a DC Micro-grid platform for solar energy sources and battery, and for practical applications such as lighting, cooking and computing. Our electric power system was designed to move central station alternating current (AC) power, via high-voltage transmission lines and lower voltage distribution lines, to house holds and businesses that uses the power in Incandescent lights, AC motors, and other AC equipment. Today's consumer equipment and tomorrow's distributed renewable generation requires us to rethink this model. Electronic devices (such as computers, florescent lights, variable speed drives, and many other household and business appliances and equipment) need direct current (DC)

input. However, all of these DC devices require conversion of the building's AC power into DC for use, and that conversion typically uses inefficient rectifiers. Moreover, distributed renewable generation (such as rooftop solar) produces DC power but must be converted to AC to tie into the building's electric system, only later to be re-converted to DC for many end uses. These AC-DC conversions (or DC-AC-DC in the case of rooftop solar) result in substantial energy losses.

One possible solution is a DC micro-grid, which is a DC grid within a building (or serving several buildings) that minimizes or eliminates entirely these conversion losses. In the DC micro-grid system, AC power converts to DC when entering the DC grid using a high-efficiency rectifier, which then distributes the power directly to DC equipment served by the DC grid. On average, this system reduces AC to DC conversion losses from an average loss of about 32% down to 10%. In addition, roof top photovoltaic (PV) and other distributed DC generation can be fed directly to DC equipment, via the DC micro-grid, without the double conversion loss (DC to AC to DC), which would be required if the DC generation output was fed into an AC system. DC micro-grids can optimize the use of electronic devices, electrical storage, and distributed generation. The DC micro-grid concept represents a decentralization of the idea of the grid, and one that advances the goals of the current Smart Grid overhaul. The DC micro-grid begins to change the paradigm from a centralized generation and distribution system of power delivery to a system that is more flexible and more accommodating of the load that has come to be: one that is more electronic, more ubiquitous, and more essential to our economy and our environment. DC

micro-grids can create power systems that are more efficient and more compatible with the fastest growing segment of the load today:

The national power grid system (AC) was not designed to handle the energy demands of the modern world, comprised primarily of DC appliances and devices. In the 50 years since the advent of the semiconductor, DC electronic devices have become ubiquitous. If you look around your home or business you will see such DC devices as TV's, stereos, computers, iPods, mobile phones, and even kitchen appliances that are powered by DC current. Any device or appliance that has a wall charger or power "brick" that gets warm is actually converting your AC current into DC current to run or charge the device. Even our lighting systems that have gone through an evolution from incandescent to fluorescent to LED can now be powered via DC ballasts and DC current. One might think that simply implementing a Renewable Energy (solar or wind) solution will solve the problem. But the DC power output must be "inverted" to AC power in order to enter into a home or building's AC standard power system. Once the power stream is in the home's AC system, then it gets converted again to DC to power all the DC devices described above. That's two conversions: DC (solar, wind) to AC (in the home system) and then back to DC (to power your device). Those two conversions yield an approximate 10-40% power loss. So the question is how do you use your Renewable Energy sources in the most efficient manner? The answer can be found in a DC micro-grid and Power Server solution implemented in the home or building, or even a small group of such.

With a DC micro-grid solution, the energy conversions from DC to AC and back to DC are minimized. The Power Server accepts both AC and DC as power inputs and then produces only DC power output. The AC power coming in gets converted to DC via a high efficiency rectifier with minimal conversion loss instead of 10-40%. This same Power Server can take the DC power input from solar or wind and be fed directly to the DC devices via the micro-grid, without the double conversion loss. Another advantage of a DC micro-grid solution is that it lends itself to battery storage solutions. A battery is simply a DC energy storage device that emits DC power when called upon to do so. Within the DC micro-grid infrastructure, a battery (or series of batteries) can play a key role in providing consistent DC power to the DC devices when there is a downward spike in available Solar

Energy, such as night time or cloudy days. The Solar Energy sources continually recharge the batteries, so unless there is a prolonged deficiency in Solar Energy, the batteries will provide the DC power to the DC micro-grid. You might be asking yourself, "What happens if there is a prolonged deficiency in Solar Energy and the batteries are drained?" That's where the Smart part of the Power Server comes in.

The smart power server which can also accept AC input, now will revert to the AC utility grid to provide clean DC power to the DC micro-grid, ensuring that all the DC devices will still be operational. To summarize the DC micro-grid solution, the Smart Power Server is the critical link that distributes clean DC power to the DC micro-grid, powering all your DC devices. It derives its power first from the Renewable Energy sources and then, only when necessary, from the AC utility grid. With onsite battery storage integrated within the DC micro-grid, an uninterruptable supply of DC power is available for all your DC devices. This paper discusses energy savings using DC Micro Grid and also effective energy conversion from solar panels.

2. DC MICRO GRID

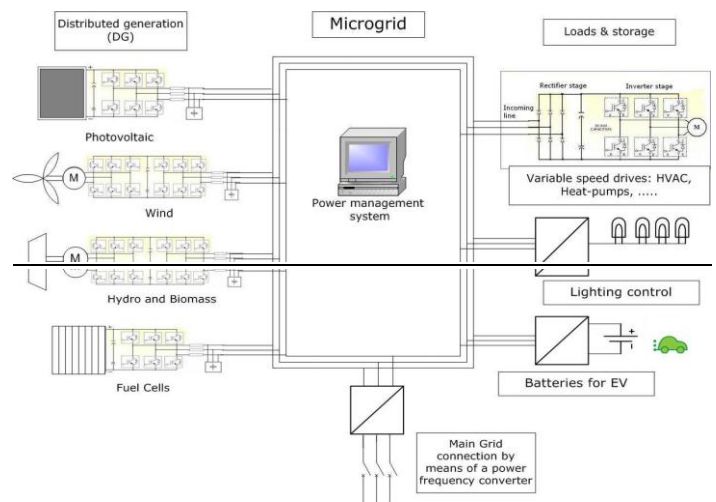

Note: This paper emphasizes only on the Solar Energy and more efficient use of solar panels.

2.1 Solar Tracking System

Solar power systems have a peak laboratory efficiency of 32% and average efficiency of 15-20% (9), it is necessary to recover as much energy as possible from it. This includes reducing inverter losses, storage losses and light gathering losses. Light gathering is dependent

on the angle of incidence of the light source providing power (i.e, the sun) to the solar cell's surface, and closer to perpendicular, the greater the power. If a flat solar panel is mounted on level ground, it is obvious that over the course of the day the sunlight will have an angle of incidence close to 90° in the morning and the evening. At such an angle, the light gathering ability of the cell is essentially zero, resulting in no output. As the day progresses to midday, the angle of incidence approaches 0°, causing a steady increase in power until at the point where the light incident on the panel is completely perpendicular, and maximum power is achieved.

As the day continues toward dusk, the reverse happens, and the increasing angle causes the power to decrease again toward minimum again.

From this background, we see the need to maintain the maximum power output from the panel by maintaining an angle of incidence close to 0° as possible. By tilting the solar panel to continuously face the sun, this can be achieved. This process of sensing and following the position of sun is known as Solar Tracking.

2.2 Sensing Elements And Tilting Dvice

Many different methods have been proposed and used to track the position of sun. The simplest of all uses an LDR - a Light Dependent Resistor. The solar cells themselves can be used as sensing device. They provide an excellent mechanism in light intensity detection – because they are sensitive to varying light and provide a near- linear voltage range that can be used to an advantage in determining the present declination or angle to the sun. The final stage involves the coupling of the sensor circuit to the stepper motor and mounting it onto the bracket. The motor used is selected depending on the weight of the solar panel. The tracking device still requires power, but a battery connected in a charging arrangement with the solar panel can supply it. It is noted that this type of arrangement can increase an overall power collection efficiency by 39% when compared to fixed pane(9).

HARDWARE COMPONENTS:

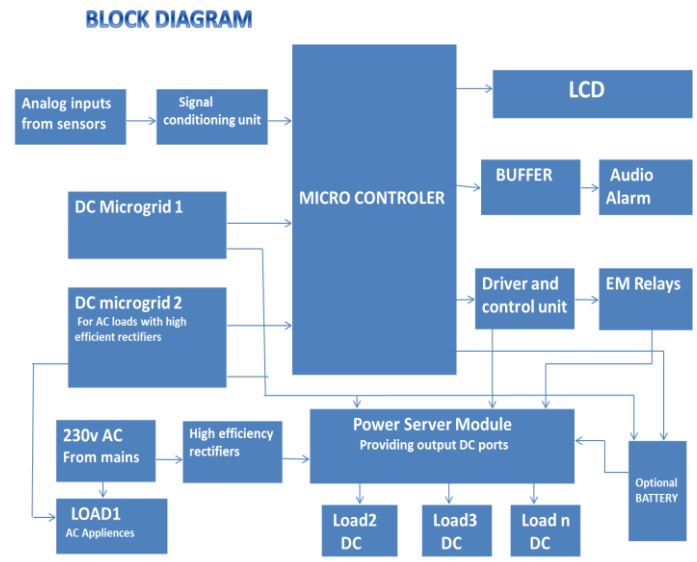

Fig 1: Block Diagram of DC Micro-grid

3. BLOCK DIAGRAM DISCRPTION

1. PIC 16F877 Micro controller
2. 16X2 LCD display modules
3. Buffer IC's 7407.
4. 12V, 7 Amps relay.
5. Buzzer to give a audio alarms
6. Signal conditioning circuit for changing voltage level and current levels.
7. Power supply section to supply DC voltage to the circuits.

Microcontroller PIC 16F877

The PIC16F877 Microcontroller includes 8kb of internal flash Program Memory, together with a large RAM area and an internal EEPROM. An 8-channel 10-bit A/D convertor is also included within the microcontroller, making it ideal for real-time systems and monitoring applications. All port connectors are brought out to standard headers for easy connect and disconnect. In-Circuit program download is also provided, enabling the board to be easily updated with new code and modified as required, without the need to remove the microcontroller.

Features:

- Includes Powerful Microchip PIC16F877 Microcontroller with 8kb Internal Flash Program Memory
- Operating Speed at 10MHz
- Direct In-Circuit Programming for Easy Program Updates

- Up to 28 I/O points with easy to connect standard headers
- Internal EEPROM
- 8 Channel 10-bit A/D Converter
- One 16-bit Timer with Two 8-bit Timers
- Power and Programming LED
- Reset Button
- Ideal as an Interchangeable Controller for Real-Time Systems

Display unit consists of 16 X 2 LCD module made from Hitachi. It will display test point number, specific section in which the test point is selected and status of decision after fault analysis etc.

4. PROGRAMMING TOOLS - KEIL μ VISION 3 IDE

The software requirement document is the official statement of what it is required for the system development (3). It includes both the user requirement for a system and detail specification of the requirements.

The developers can make any change in the feature will have to go through a formal change approval process. The developer is responsible to ask for clarification wherever necessary and will not make any changes without the permission for client.

The main objective is to check the given board thoroughly and give a decision about the fault and no fault conditions at different sections of the circuits.

In addition send the control signals to give audio alarm and turn off the power during abnormal conditions.

5. COMPONENTS

5.1 Multi Tap Transformers

Transformer is an electrical device used to convert AC power at a certain voltage level to AC power at a different voltage, but at the same frequency. This transformer has multiple secondary coils to feed a number of electrical loads

5.2 High Efficient Rectifiers

- Rectifier is an electronic circuit which converts AC supply to DC.
- Traditional rectifiers have very poor efficiency

ranging from 40-60%.

- High efficient rectifiers have efficiency ranging from 80% -90%.

5.3 Battery Bank

- A battery is simply a DC energy storage device that emits DC power when called upon to do so.
- Within the DC micro-grid infrastructure, a battery (or series of batteries) can play a key role in providing consistent DC power to the DC devices when there is a downward spike in available Renewable Energy, such as night time or cloudy days.
- The Solar Energy sources continually recharge the batteries, so unless there is a prolonged deficiency in Solar Energy, the batteries will provide the DC power to the DC micro-grid.

6. FUTURE ENHANCEMENT

- Number of test points can be increased, so that more number of sections can be checked thoroughly.
- Instrumentation amplifier and precision scaling circuits can be adopted to give still higher accuracy in the measurement of parameters (7).
- The speed of operation can be increased by processing the test points parallelly by using multiple ADCs.
- Range of wireless transmission can be extended by using long range RF transmitters and receiver chips working in gigahertz range.
- Component testing unit can be added to the system
- The performance can be improved by adding software for more number of boards, by increasing more stages of signal conditioning circuits to tackle different voltage and current levels sensor can also be added to this system to safe guard the circuits under tests due to over voltage, under voltage, temperature, etc.

7. CONCLUSION

This model is working satisfactorily for all the above said test conditions. The smart DC micro-grid can save nearly 15% of energy and also the solar tracking system can enhance the power collection efficiency by around 30%. As a whole the combination of the micro grid and the solar tracking system adopted in solar panels can give an over all increase of power by 20%.

REFERENCES

- [1] "The 8051 Microcontroller and embedded systems" by Muhammad Ali Mazidi and Janice Gillispie Mazidi., Sixth edition, Pearson Education.
- [2] "The 8051 Microcontroller architecture, programming and applications" by Kenneth J Ayala, second edition, Penram International Publishing.
- [3] "Design with PIC microcontrollers"- John B. Peatman, First edition, Pearson Education.
- [4] "Embedded Microcomputer system-Real time interfacing" by J.W.Valvano, First edition, Thomson Learning Publishing, 2000
- [5] "Real time systems" by Jane W.S.Liu, Pearson Education Asia Pub, 2004.
- [6] "An Embedded software primer" by David E.Simon, Pearson Education, 1999
- [7] "Analysis & design of Integrated electronic circuits" by Paul. M, Second edition, John Wiley & sons
- [8] Optimal Fuzzy PID Controller for multi input and output by K.Sridhar, A.B.Patil, M.S.Kmbhar.
- [9] "Solar Tracking System: More Efficient use of Solar Panels" by J. Rizk and Y. Chaiko