

# Oscillation Based Testing for Low Voltage Two Stage Operational Transconductance Amplifier

Maninder kaur, Jasdeep Kaur

**Abstract**— The paper describes the design for testability (DFT) of low voltage two stage operational transconductance amplifiers based on oscillation based testing (OBT). The oscillation-test strategy is a low cost and robust test method for mixed-signal integrated circuits. Being a vectorless test method, it allows one to eliminate the analog test vector generator. Circuit under test is transformed to oscillators using very simple techniques. The tolerance band of the oscillation frequency is determined by a Monte Carlo analysis taking into account the nominal tolerance of all circuit under test components. Seventeen bridging faults and nine open faults have been analyzed in proposed work. Simulation results for two stage operational transconductance amplifier using a 0.18 $\mu$ m CMOS technology show that the proposed oscillation-based test strategy has more than 92% fault coverage and, with a minimum number of extra components, requires a negligible area overhead.

**Index Terms**—Circuit under test (CUT), Faults, Fault Injection Transistor (FIT), Operational Transconductance Amplifier (OTA), OBT, Monte Carlo Simulation.

## 1 INTRODUCTION

IN the last fifteen years or so, tremendous progress has been made in integrated analogue operational transconductance amplifier research and development, however, testability of analog OTA is still rather unstructured since testability is not yet a precisely defined term in the analogue world. Consumer electronic systems often require design for testability (DFT) techniques, including built-in self-test structure for analogue and mixed-signal ICs [1]. DFT for analogue circuits is one of the most challenging tasks in mixed-signal ASIC design due to the sensitivity of the circuit parameters to component variations and process technologies [2],[3]. Hence, we need to explore and investigate some cost effective, robust test method without any additional signal generation circuit. The DFT of analog circuits can be generally divided into two categories; the first deals with controllability and observability of the internal nodes and the second is to convert the circuit under test (CUT) function and generate an output signal which contains the CUT performance to determine its malfunction[4],[5][6].

In this paper, we present an easily implemented and low cost test approach to improve the fault diagnosis and testability of typical two-stage CMOS operational transconductance amplifier using DFT based oscillation test methodology [7]. The proposed test method is simple and provides good fault coverage with little circuit modification. The OTM is a low cost and robust test method for mixed signal integrated circuit and has been very effective in detecting physical defects such as open, shorts and bridging defects. Being vector-less technique, it allows one to eliminate the analog test vector generator [8], [9]. In this test methodology, complete circuit is divided into small functional blocks like amplifier, comparator,

filter etc and each block is transformed to a circuit which oscillates. The oscillation frequency of the CUT is compared with nominal frequency of fault free circuit. Faulty behavior is then indicated by deviations in the frequency of oscillations with respect the frequency under fault-free conditions. The tolerance band of the oscillation frequency is determined by a Monte Carlo analysis taking into account the nominal tolerance of all CUT components [10]. The testability has also been enhanced in the testing procedure using a simple fault-injection technique. The approach is attractive for its simplicity and robustness.

The format of this paper is as follows; two stage operational transconductance amplifier and analog fault modeling are discussed in Section 2 and section 3 respectively. Section 4 introduces OTA to oscillator conversion schemes. Test simulation results are given in Section 5 and Section 6 contains conclusions.

## 2 TWO STAGE OPERATIONAL TRANSCONDUCTANCE AMPLIFIER

Operational transconductance amplifier is voltage controlled current source. It is an amplifier whose differential input voltage produces an output current [11]. There is usually an additional input for a current to control the amplifier transconductance. It replaces operational amplifier because of its high bandwidth, high voltage swing, high SNR even at low voltages and also due to its unique characteristic suited for applications such as gain control, multiplexing, comparator, analog modulation, active-c filter, oscillator etc [12]. Thus OTA constitute as a major building block in the analog designing. In OTA the output current is linear function of differential input voltage as shown in equation 1.

$$I_{OUT} = (V_{in+} - V_{in-}) \times G_m \quad (1)$$

The basic circuit diagram of two stage OTA is shown in fig 1 with differential amplifier and current mirror as first stage

- Maninder kaur is currently pursuing doctorate degree program in Electronics and communication engineering in Shri Venkateshwara University, Gajraula U.P, India, PH-09968747085. E-mail: [mindersaini82@gmail.com](mailto:mindersaini82@gmail.com)
- Jasdeep Kaur is currently working as Associate Professor in Delhi Technical University for Women, Kashmere Gate, New Delhi, India. E-mail: [jasdeepkaur@yahoo.com](mailto:jasdeepkaur@yahoo.com)



Or equivalently

$$Re(f_{CUT}(j\omega)f_H(j\omega)) = 1 \tag{4}$$

$$Im(f_{CUT}(j\omega)f_H(j\omega)) = 1 \tag{5}$$

This condition is known as Barkhausen criterion which states that the signal must transverse the loop with no attenuation and no phase shift at the oscillation frequency [17]. In this work, CUT is converted into oscillator by using Wien bridge network [18]. The Wien bridge network is connected to the positive terminal of the CMOS OTA as shown the fig.3. The component values that we have used here are  $R1 = R3 = 10K\Omega$ ,  $R2 = 3 K\Omega$ ,  $R4 = 1K\Omega$ ,  $C3 = C1 = 16nF$  for simulation to achieve self-sustained oscillation.

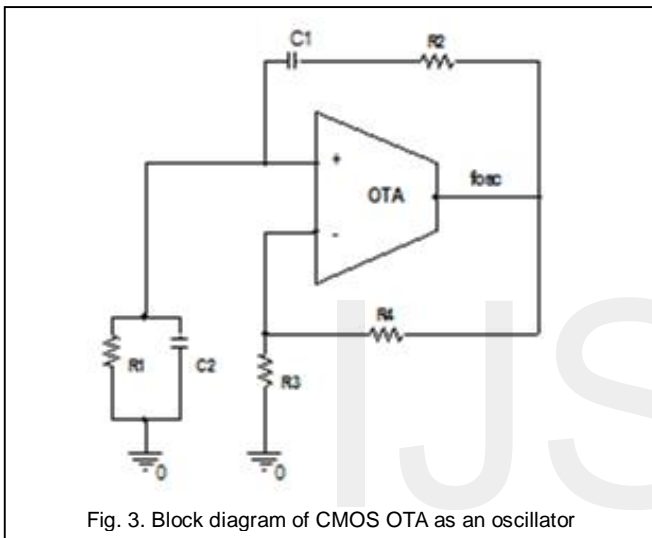

Fig. 3. Block diagram of CMOS OTA as an oscillator

Natural oscillation frequency is determined by the Fast Fourier Transform (FFT) analysis of oscillatory circuit. The schematic diagram of OTA as an oscillator is shown in fig.4.

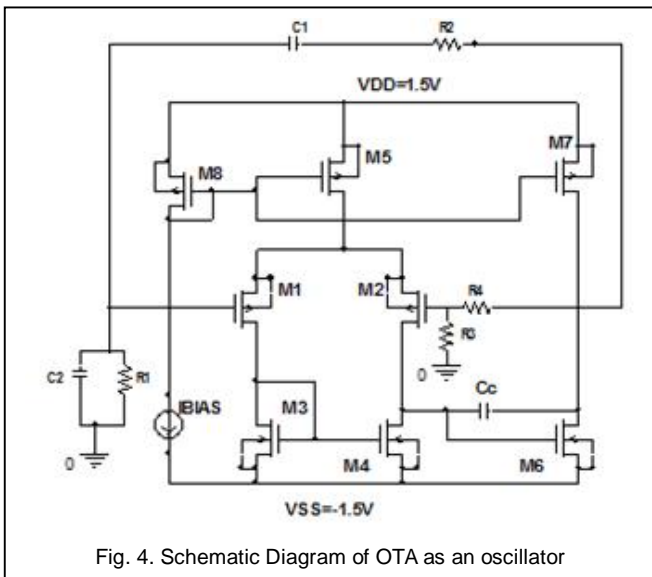

Fig. 4. Schematic Diagram of OTA as an oscillator

### 5 SIMULATION RESULTS

The testable OTA in fig.2 were simulated using PSPICE level 7 models 0.18μm CMOS technology for verification of the proposed OBT structures. The aim of this work is to show that oscillation-test strategy is able to detect the catastrophic faults as well as parametric faults. For the test purposes, OTA is converted into to an oscillator using quite simple technique which has nominal oscillation frequency of 752KHZ. Fig.5 shows time domain oscillation response of CUT, time domain oscillation response of the converted corresponding oscillator and the frequency response of the circuit under test. The fault-free oscillation frequency observed to be 750KHZ which was slightly shifted from the cut-off frequency of the circuit [18], [19].

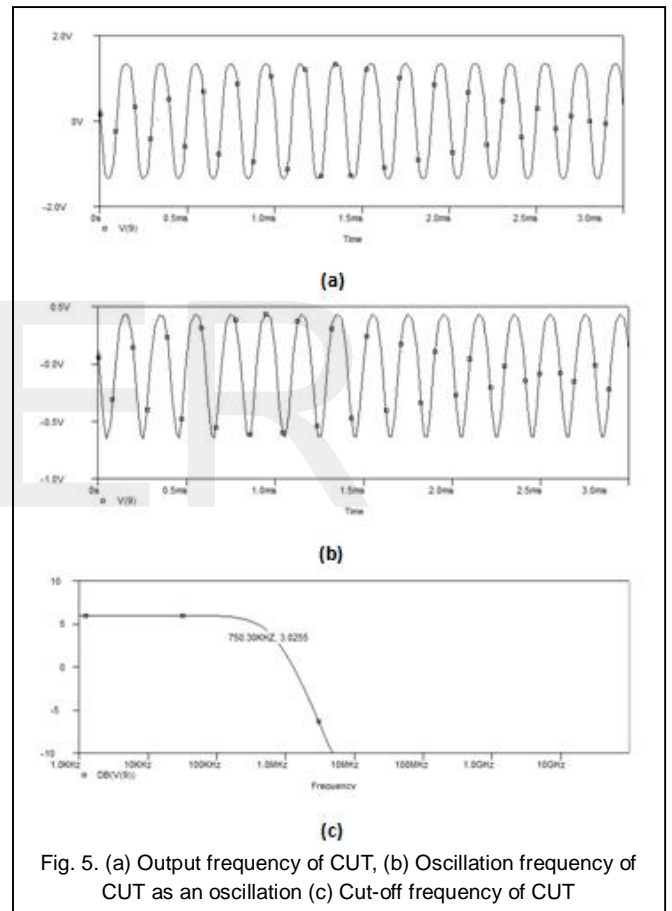

Fig. 5. (a) Output frequency of CUT, (b) Oscillation frequency of CUT as an oscillation (c) Cut-off frequency of CUT

To quantify the fault coverage and efficiency of the OBT strategy, a number of different faults were injected into the circuit under test according to the methodology described. To determine the undetectable tolerance band for the frequency, a Monte Carlo analysis was performed. The Fast Fourier Transform (FFT) of the output signal shows that the oscillation signal has lower and upper frequency deviation bounds of -4.25% and +5.05% respectively. The faults which produced oscillation frequency deviation outside this tolerance band were considered detectable.

In the present work, total twenty six faults which include sev-

enteen short faults and nine open faults have been introduced in CUT oscillator. The value of W/L of FIT is taken as 1/0.5. It is observed that the twenty faults out of twenty six fault deviate from nominal oscillation frequency range whereas four faults resulted in loss of oscillation, thus twenty four faults have been detected with fault coverage of 92%.the results also show that two faults could not be detected, since the deviation observed in oscillation frequency with respect to nominal frequency was within the tolerance limit. Tables 1 present the effects of the injected faults on the oscillation frequencies and percentage deviations from the fault-free frequency.

**TABLE 1**  
**INJECTED FAULTS IN THE CUT**

Component	$\Delta C/C$	$\Delta f_{osc}/f_{osc}$	$\Delta C/C$	$\Delta f_{osc}/f_{osc}$	$\Delta C/C$	$\Delta f_{osc}/f_{osc}$
M1	GDS	20%	DSS	-9.93%	OPEN	NO%
M2	GDS	-10%	DSS	-9.3%	OPEN	-6.91%
M3	GDS	3%	DSS	-25%	OPEN	-35.77%
M4	GDS	NO	DSS	2%	OPEN	180%
M5	GDS	32.18%	DSS	6.38%	OPEN	23%
M6	GDS	-30.5%	DSS	-10.33%	OPEN	NO
M7	GDS	6.38%	DSS	NO%	OPEN	110%
M8	GDS	-30%	DSS	12.5%	OPEN	-20.8%
Cc	SSF	12.5%	-	-	OPEN	-10.39%

$\Delta C / C$ : Percentage of the faults injected into component C,  $\Delta f_{osc} / f_{osc}$ : Variation of the oscillation frequency from its nominal value, NO: No oscillation, GDS: Gate – Drain Short, DSS: Drain - Source Short, SSF: Struck Short Fault

The obtained results, presented in table1 show that both short and open faults can be detected with high fault coverage. Table 2 summarizes the fault coverage obtained by oscillation testing in terms of short and open faults injected.It can be seen from the table 2 that the overall fault coverage obtained for all faults injected was 92%.

**TABLE 2**  
**SIMULATED FAULT COVERAGE OF OSCILLATION TESTING**

FAULT TYPE	TOTAL FAULTS INJECTED	FAULTS DETECTED (WITH OSCILLATION)	FAULTS DETECTED (WITHOUT OSCILLATION)	FAULTS UNDETECTED (WITH OSCILLATION)	FAULT COVERAGE
SHORT	17	13	2	2	88.23%
OPEN	9	7	2	0	100%
TOTAL	26	20	4	2	92.3%

## 6 CONCLUSION

In this paper, we have proposed a vectorless, dynamic DFT technique for low voltage two stage operational transconductance amplifiers, based on converting the circuit into an oscillator using wein-bridge oscillator. The OBT technique needs only measurement of the frequency deviation to detect faults. Hence requires short test times and has good immunity to noise. The design is easily implemented with little area overhead and has negligible impact on circuit performance. Fault simulation results show that the proposed oscillation-based test technique provides high fault coverage of 92% and is ca-

pable of simultaneously detecting single and multiple faults. The advantage of the proposed solution is that they require only minor circuit changes and is a vector-less solution for fault detection.

## REFERENCES

- [1] A. Grochowski, D. Bhattacharya, T.R. Viswanathan and K. Laker, "Integrated circuit testing for quality assurance in manufacturing: history, current status, and future trends," IEEE Trans. on Circuits and Systems II: Analog and Digital Signal Processing, vol. 44, no. 8, pp. 610-633, Aug. 1997.
- [2] Linda S. Milor, Member, IEEE, "A Tutorial Introduction to Research on Analog and Mixed-Signal Circuit Testing," IEEE Transactions on circuits and system-II : Analog and digital Signal processing, vol 45, no. 10 october 1998.
- [3] Michael L.Brushnell and Vishwani D Aggarwal, Essentials of Electronic Testing for Digital, Memory and Mixed –Signal VLSI circuits , Kluwer Academic Publication.
- [4] Stanley L. Hurst, VLSI Testing: Digital and Mixed Analogue/Digital Techniques, Institution of Engineering and Technology, 1998.
- [5] G. Huertas, D. Vazquez, E.J. Peralias, A. Rueda, J.L. Huertas, "Practical Oscillation-Based Test of Integrated Filters," IEEE Design & Test of Computers, vol. 19, no. 6, pp. 64-72, 2002.
- [6] Peter Mrak, Anton Biasizzo and Franc Novak, "Measurement of Accuracy of Oscillation-Based Test of Analog-to-Digital Converters," ETRI Journal, vol 32, no 1, February 2010.
- [7] K. Arabi and B. Kaminska, "Design for Testability of Embedded Integrated Operational Amplifiers," IEEE Solid-State Circuits, vol. 33, pp. 573-581, april 1998.
- [8] Bijay K Sharma, "Oscillation Based Test Method of Parameterization of Open op amp and its authentication," AEU- International Journal of Electronics and Communication, vol. 68, issue 7, pp 595-601, January 2014.
- [9] K. Arabi and B. Kaminska, "Testing Analog and Mixed-Signal Integrated Circuits using Oscillation-Test Method," IEEE. Trans. on Computer-Aided Design of Integrated Circuits and Systems, pp. 745-753, July 1997.
- [10] Sankari M.S and P. Sathish kumar, "Oscillation Test methodology of Built- In Analog Circuits," IJECR, vol. 2, issue no. 3, pp 868-877, May-June 2012.
- [11] Bhavesh H.Soni, Rasika N Dhavse, "Design of OTA using 0.35µm Technology," International Journal of Wisdom Based Computing, vol.1, August 2011.
- [12] Mohammad Yavari, Nima Maghari and Omid Shoaei, "An accurate analsis of slew arte for two stage CMOS opamps." IEEE Transaction on Circuits and Systems 11, vol. 2, n0. 3, pp 164-167, March 2005.
- [13] Karim Arabi and Bozena Kaminska, "Parametric and Catastrophic Fault coverage of Analog Circuits in Oscillation-Test Methadology," Proceeding of 15th IEEE VLSI Test Symposium (VTS'97).
- [14] Gloria Huertas, Diego Vázquez, Eduardo J. Peralías, Adoración Rueda, and José Luis Huertas, "Testing Mixed-Signal Cores: A Practical Oscillation-Based Test in an Analog Macrocell," IEEE Design & Test of Computer, Nov-Dec 2002.
- [15] Miona Andrejevic Stosovic, Miljana Milic and Vanco Litovski, "Analog filter diagnosis using the Oscillation Based Method," Journal of Electrical Engineering, vol. 63, no. 6, pp 349-356, 2012.
- [16] Karim Arabi and Bozena Kaminska, "Oscillation-Test Methodology for Low-Cost Testing of Active Analog Filters," IEEE transaction on instrumentation measurement, vol.48, no 4, August 1999.
- [17] Raja Sen, Arko Banerjee, Satyaki Banerjee, Sayanta Roychowdhury, "Design of an oscillator using CMOS operational transconductance amplifier," International Journal of electrical and computing engineering, vol. 1, issue 1, July 2014.
- [18] Diego Vazquez, Gloria Huertas, Gildas Leger, Eduardo Peralias, Adoracion Rueda and Jose Luis Huertas, "On-Chip Evaluation of Oscillation-Based-Test Output Signals for Switched-Capacitor Circuits," Journal of Analog Integrated Circuits and Signal Processing, vol. 33, pp 201 –211, November 2002.
- [19] Masood-ul-Hasan, Yichuang Sun, Xi Zhu and James Moritz, "Osillation-based DFT for second order OTA-C filter" IEEE transaction 2008.