

# GARBAGE RECYCLING AND INTIMATION SYSTEM

S.Karthikeyan, S.Bilal Ahamed, V.Prabhakaran.

Students, Department of EEE

Narasu's Sarathy Institute of Technology

Salem, Tamilnadu, India

karthisiva811@gmail.com

kprabha5014@gmail.com

bilabillu96@gmail.com

M.r.C.Suresh.M.E.,

Assistant Professor, Department of EEE

Narasu's Sarathy Institute of Technology

Salem, Tamilnadu, India

suresheee85@gmail.com

P.Sudarsan M.E., Phd

Head of the Department

Assistant Professor Department of EEE

## ABSTRACT

Rapid increase in population. We see present day, many times Dust bin are placed near public places in the cities/villages are filled due to increase in the waste every day. so efficient method to dispose the waste has been designed with Gsm system. If the disposal of waste is not proper done it creates unhygienic condition for the people and it creates ugliness to that place. At the same time bad smell is also spread this leads in causes some deadly diseases & human illness, to avoid such a situation we are planning to design "GSM Based Waste Management for Smart Cities". In this proposed designed System there are multiple dustbins located throughout the city, these dustbins are provided with IR sensor which helps in level of the garbage bins and an so that it is easy to identify which garbage bin is full.

## INTRODUCTION

Due to increase in population .we have few garbage bins placed in cities which is overflowing and it checked by local

authorities there are all types of garbage all disposed in bins and it all dumped together. So we designed the new concept of waste managment disposal using automatic garbage level detecting from ultrasonic sensors and it will provide real time information about dustbins which is situated city. we classified waste in following categories:

- Biological waste
- Recyclable waste
- Plastic Waste

## EXISTING SYSTEM

In 'smart garbage management system' system, the level of garbage in the dustbins is detected with the help of Sensor systems, and communicated to the authorized control room through GSM system. Microcontroller is used to interface the sensor system with GSM system. A GUI is also developed to monitor the desired information related to the garbage for different selected locations. This will help to manage the garbage

collection efficiently. Here in this system, Infrared (IR) sensor is used for garbage level detection. IR sensor radiates light which is invisible to the human eye because it is at infrared wavelengths, but it can be detected by electronic devices. GSM module is used for communication purpose, to send message to the control room when the container is full. Arduino is used to interface the sensor and GSM module.

The IR sensor arrangement is act as level detector .The output of level detector is given to the microcontroller. The AT commands are used to facilitate the messaging service through the GSM Module. This program is burned in the microcontroller with the help of Arduino software (IDE). These messages consist of information of garbage levels of respective dustbins. Depending on the information sent to control room, the authority informs the concern person of the respective area about garbage level. Then the concerned person makes sure that the garbage of that particular area is collected by sending the cleaning vehicles.

### PROPOSED SYSTEM

The system will get the input through the dust collecting person through switches and sends signal to the Micro controller makes the realy to rotate conveyor belt. When the belt starts rotating clockwise the dust bin's lid is automatically closed, simultaneously the waste is dumped into the underground garbage container placed at the ground floor. Here module is used to control and monitor the waste and the information will be sent to the particular organization and the common man. The mobile shows the collection of waste and the particular date and arrival time of the vehicle.

### BLOCK DIAGRAM

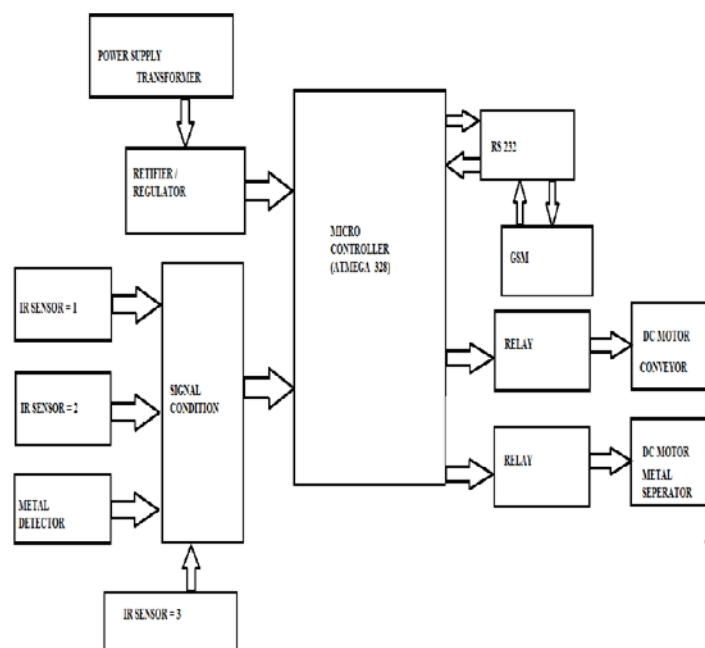

### BLOCK DIAGRAM DESCRIPTION

The bins are infixed with level sensor IR sensor to indicate the level of garbage in the bin, GSM module to instruct the status of the bin. If the opted place of owner has all the resources given to the implementer then, the installation of paper will be executed. These tech bins recycling & non-recycling waste are kept on the either corner side of the apartment in each floor where the owner opts, but it should be a centralized view to ease the construction process. These bins has closing lids which closes as there is a 80% garbage in the particular bin. If there is a case that all the bins attached to the conveyor belt on either side contains 80% garbage then automatic rotation of the conveyor belt is done by using RF technology.

## HARDWARE REQUIREMENTS

The hardware requirements for the system are as follows:

### ATMEGA328P Micro Controller

The atmega328P is the one of the most advanced micro controller from micro chip. It is widely used for the experimental and modern application because of its low price, high quality, multiple features which has inbuilt ADC/DAC, timer, shift registers.



### GSM MODULE:

GSM Modem can accept any GSM network operator SIM card and act just like a mobile phone with its own unique phone number. Advantage of using this modem will be that you can use its RS232 port to communicate and develop embedded applications. Applications like SMS Control, data transfer, remote control and logging can be developed easily using GSM as shown.

The modem can either be connected to PC serial port directly or to any microcontroller through MAX232. It can be used to send and receive SMS or make/receive voice calls. It can also be used in GPRS mode to connect to internet and do many applications for data logging and control. In GPRS mode you can also connect to any remote FTP server and upload files for data logging. This GSM modem is a highly flexible plug and play

quad band **SIM900A** GSM modem for direct and easy integration to RS232 applications. Supports features like Voice, SMS, Data/Fax, GPRS and integrated TCP/IP stack.



### IR SENSOR

IR transmitter and receiver LEDs have been around for a long time so the technology is already seen in mainstream society). The Sharp IR Range Finder works by the process of triangulation. A pulse of light (wavelength range of 850nm +/-70nm) is emitted and then reflected back (or not reflected at all). When the light returns it comes back at an angle that is dependent on the distance of the reflecting object. Triangulation works by detecting this reflected beam angle - by knowing the angle, distance can then be determined as shown below



The IR range finder receiver has a special precision lens that transmits the reflected light onto an enclosed linear CCD array based on the triangulation angle. The CCD array then determines the angle and causes the rangefinder to then give a corresponding analog value that can be read by a microcontroller. Additional to this, the Sharp IR Range Finder circuitry applies a modulated frequency to the emitted IR beam. This ranging method is almost immune to interference from ambient light, and offers amazing indifference to the colour of the object being detected. In other words, the sensor is capable of detecting a black wall in full sunlight with almost zero noise.

## DC MOTOR

DC motors are widely used, inexpensive, small and powerful for their size. Reduction gearboxes are often required to reduce the speed and increase the torque output of the motor. Although recent developments in stepper motor technologies have come a long way, the benefits offered by smooth control and high levels of acceleration with DC motors far outweigh any disadvantages. Several characteristics are important when selecting DC motors and these can be split into two specific categories. The first category is associated with the input ratings of the motor and specifies its electrical requirements, like operating voltage and current. The second category is related to the motor's output characteristics and specifies the physical limitations of the motor in terms of speed, torque and power. In case of geared motors another attribute that can be specified is the gear ratio. The higher the ratio, the stronger robot (more torque; less speed), the lower, the faster robot (less torque; more speed). Direction of rotation of a motor can be controlled by the direction of voltage applied across the terminals. Speed of the motor can be controlled by varying the voltage applied and in cases where

only digital signals are available by using Pulse Width Modulation (PWM).

## APPLICATIONS AND ADVANTAGES

- 1) To collect dustbins placed at public places in city.
- 2) This paper can also be used in college / university campus
- 3) This paper can also be used in companies
- 4) Many times Garbage dust bin is overflowed and many animals like dog or goat enters inside or near the dustbin. This creates a bad scene. Also some birds are also trying to take out garbage from dust bin. This paper can avoid such situations.

## FUTURE SCOPE

There is a great scope for the modifications of the Smart Dustbin in future. The system can be improved by adding new functionalities. Dumping of the waste was manual in Smart dustbin this can be automated by fixing a robot arm or a tipper. The path tracking can be GPS enabled and the dustbins can be monitored through a GUI. The Smart dustbins can be well widely used in the Smart buildings of Smart cities.

## CONCLUSION

This paper shows the implementation of smart garbage management system using ultrasonic sensors, microcontroller and GSM module. This system assures the cleaning of dustbins soon when the garbage level reaches its maximum. If the dustbin is not cleaned in specific time, then the record is sent to the higher authority who can take appropriate action against the concerned contractor. We have implemented real time waste management system by using smart dustbins to check the fill level of smart dustbins whether the

dustbin are full or not. In this system the information of all smart dustbins can be accessed from anywhere and anytime by the concern person and he/she can take a decision accordingly. By implementing this proposed system the cost reduction, resource optimization, effective usage of smart dustbins can be done .

## REFERENCES

- [1] Basic Feature, “solid waste management paper by MCGM,”
- [2] Microcontronics Technologies, “GSM based garbage and waste collection bins overflow indicaator,” September 2013
- [3] “City Garbage collection indicator using RF and GSM technology”
- [4] A. S. Bhat, B. Raghavendra, and G. N. Kumar, “Enhanced passive RFID based disaster management for coal miners, “International Journal of Future Computer and Communication 2013, vol. 2, no. 5, October 2013, Singapore, 2013.
- [5] M. Aparajitha, K. Bhanupriya, B. Smitha Shekar, and G. Narendra Kumar, “Performance evaluation of IEEE 802.11p for vehicular traffic congestion control (2011)”, Journal of Information and Communication Technologies, vol. 1, issue 6, November 2011 M. Young, The Technical Writer’s Handbook. Mill Valley, CA: University Science, 1989