

Boiler Drum Level Control by Using Wide Open Control with Three Element Control System

T. Rajkumar*, Mrs.V.M.Ramaa Priyaa**

* Studying M.TECH – E&I, Barath University, Chennai.

Email: rajaainstrumentation@gmail.com

**Assistant Professor-E&I, Barath University, Chennai.

Email: ramaa.priyaa@gmail.com

ABSTRACT

The boiler drum level control with DCS in thermal power station, with some modification is taken as a project work and the paper presentation is given below.

Steam generation in the boiler is proportional to the power generation by supplying a required steam flow to the turbine. As the steam flow is proportional to the Power generation, always there will be fluctuations in the drum level. If the drum level goes below the desired lower drum level, there will be a every possibility of starvation of water tubes inside the furnace is expected and the boiler may get damaged and if the water level in the drum raises above the desired upper drum level, there will be a carryover of water particles in the dry steam flowing to the turbine and thus the turbine blade damage is expected. In order to meet out the steam requirement , to safeguard the boiler water tubes and to safe guard the turbine blades the boiler drum water level control plays an important role in thermal power station.

The main objective of the boiler–turbine system control is to meet the load demand of electric power while maintaining the pressure and water level in the drum within tolerances. The advanced control algorithm is derived for changing function of single element to three element transfer, Which is Wide Fast Combination of batch and continuous type operations such that plant steam load characteristics varies continuously and usually unpredictably. Here we used the wide opening technology for conservation of the energy.

Key word: Boiler drum, three elements, feed water flow, steam flow and water level in drum.

1. Introduction

The control system for a boiler–turbine unit usually needs to meet the requirement of the amount of water in the steam drum must be maintained at a desired level to prevent overheating of the drum or flooding of steam lines. This is critical for the safe and economic operation of a power plant.

1. Learn why drum level control is critical for boiler safety.
2. Boiler damage due to low water level is one of the largest issues.
3. Proper drum level control minimizes downtime and cost.
4. Drum level control is critical to good boiler operation, as well as safe boiler operation.

The drum level must be controlled to the limits specified by the boiler manufacturer. If the drum level does not stay within these limits, there may be water carryover. If the level exceeds the limits, boiler

water carryover into the super-heater or the turbine may cause damage resulting in extensive maintenance costs or outages of either the turbine or the boiler. If the level is low, overheating of the water wall tubes may cause tube ruptures and serious accidents, resulting in expensive repairs, downtime, and injury or death to personnel. A rupture or crack most commonly occurs where the tubes connect to the drum.

Providing tight water level control in a drum is accomplished by utilizing one of three types of drum level control: single-element, two-element, or three-element.

The term 'single-element' is derived from single variable: drum level influence on the feed-water valve position. While single-element drum level control is acceptable for steady boiler load conditions; as load changes become more frequent, unpredictable, or severe; this type of level control cannot respond quickly enough to compensate.

The term 'two-element' is derived from two variables: steam flow and drum level influence on the feed-water valve position.

The term 'three-element' is derived from three variables: steam flow, feed water flow and drum level influence on the feed-water valve position. Wide Fast Combination of batch and continuous type operations such that plant steam load characteristics varies continuously and usually unpredictably.

1.1 Existing control system

- Drum Level Control is implemented in the PID controller.
- Changeover between single element and three element causes drum level variation.
- Feed-water flow is controlled through Feed water regulating control valve by two constant speed motor driven pumps.
- Drum level compensation includes steam temperature, drum pressure.
- Auxiliary power consumed by the constant speed motor is high.
- Controlling Feed water flow through the control causes large flow variations.

1.2 Proposed work

- Drum Level Control Algorithm is implemented in the Advanced Adaptive PID Controller Block in the FCP270 Field Control Processor. This project uses four advanced PID controller Blocks, Signal selector Blocks and Characterizer Blocks.
- There are six Differential Pressure type Level Transmitters are used to measure the drum level, out of which three transmitters are located on the left side of the drum and three are located on the right side of the drum. Four Pressure transmitters are to measure the drum pressure for density compensation.
- Signal Selector block provides automatic selection of process variable depending upon the status of the variables. Average value of left and right side level transmitters are used as compensated drum level measurement.
- Calculated value of drum level measurement is used for the generation of alarm shut down signals for Boiler such as drum level Low, Low Low, High and High High.

- Bumpless transfer between single element and three element control by using Steam Flow as a Control Element.
- One Motor Driven Boiler Feed Pump (MDBFP) and Two Turbine Driven Boiler feed pumps (TDBFP) are used to control feed water flow .During Unit Start up MDBFP is used to feed the water to drum and after synchronizing the unit TDBFPs will come into line.
- Use of Variable Speed Pump motor for feed water flow control decreases power consumed by the motor during low load operation.
- In addition to the differential pressure type drum level measurement, Hydra step based Intelligent Water Level Indicator and Electric Water Level Indicator with Drum level Television is located in the Operator Station for monitoring.

2. Boiler Drum Level Control

The drum level must be controlled to the limits specified by the boiler manufacturer. If the drum level does not stay within these limits, there may be water carryover. If the level exceeds the limits, boiler water carryover into the super-heater or the turbine may cause damage resulting in extensive maintenance costs or outages of either the turbine or the boiler. If the level is low, overheating of the water wall tubes may cause tube ruptures and serious accidents, resulting in expensive repairs, downtime, and injury or death to personnel. A rupture or crack most commonly occurs where the tubes connect to the drum. Damage may be a result of numerous or repeated low drum level conditions where the water level is below the tube entry into the drum.

When the drum level gets too low, the boiler must have a boiler trip interlock to prevent damage to the tubes and cracks in the tubes where they connect to the boiler drum. The water tubes may crack or break where they connect to the drum, or the tubes may rupture resulting in an explosion. The water tube damage may also result in water leakage and create problems with the drum level control. The water leakage will affect the drum level because not all the water going into the drum is producing steam.

Poor level control also has an effect on drum pressure control. The feed water going into the drum is not as hot as the water in the drum. Adding feed water too fast will result in a cooling effect in the boiler drum reducing drum pressure and causing boiler level shrinkage.

3. Shrink and Swell

Shrink and swell must be considered in determining the control strategy of a boiler. During a rapid increase in load, a severe increase in level may occur. Shrink and swell is a result of pressure changes in the drum changing water density. During a rapid increase in load, a severe rise in level may occur because of an increase in volume of the bubbles. This increased volume is the result of a drop in steam pressure from the load increase and the increase in steam generation from the greater firing rate to match the load increase. If the level in the drum is too high at this time, it may result in water carryover into the super heater or the turbine. The firing rate cycle can result in drum pressure cycles. The drum pressure cycles will cause a change in drum level.

The firing rate change has an effect on drum level, but the most significant cause of shrink and swell is rapid changes in drum pressure expanding or shrinking the steam bubbles due to load changes. Typically, for redundancy, there are three different methods used to measure drum level. In the “Boiler drums/level measure SATURATED STEAM ’s eye technology is a direct reading level measurement. The differential pressure transmitter represents the level control measurement.

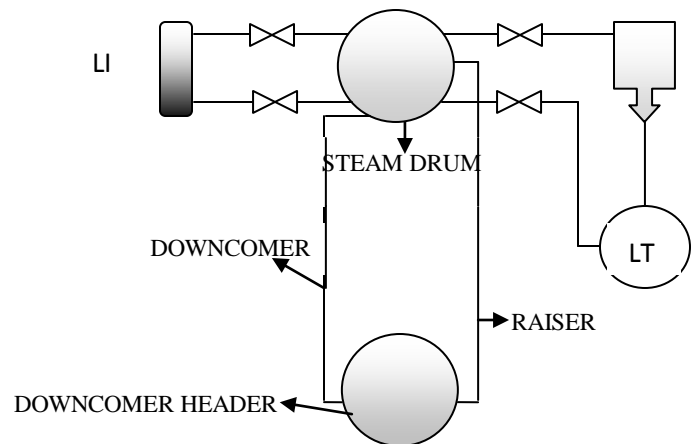

Figure-2 Boiler drum level management

4. Drum Level Measurement

The FIG-2 is an example of the arrangement of a differential drum level measuring transmitter. The differential transmitter output signal increases as the differential pressure decreases. The differential pressure range will vary between 10 and 30 inches, depending on the size of the boiler drum, with a zero suppression of several inches. On the high pressure side of the measuring device, the effective pressure equals boiler drum pressure plus the weight of a water column at ambient temperature having a length equal to the distance between the two drum pressure connections. On the low pressure side, the effective pressure equals boiler drum pressure, plus the weight of a column of saturated steam having a length from the upper drum pressure connection to the water level, and the weight of a column of water at saturation temperature having a length from the water level to the lower drum pressure connection.

On high pressure boilers, a condensate pot is connected on the top water leg to keep the leg full of condensate. If the condensate level varies in the top connected leg, the drum level measurement will not be accurate. On low pressure boilers, a condensate pot may not be required. The “Drum level connections” image is an example of the correct method of installing a differential pressure transmitter. The correct installation allows the sediment to remain in the blow down line without getting into the transmitter.

Problems with drum level measurement can be a result of improper installation of the sensing legs from the boiler drum to the transmitter. It is critical that lines be sloped at least a half inch per foot from the boiler drum to the transmitter. If not properly

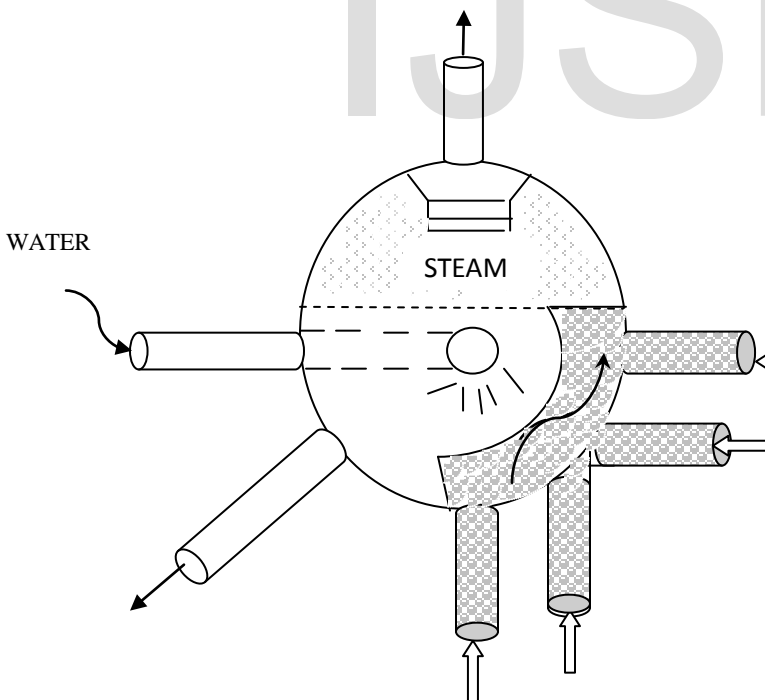

Figure-1 the water in the steam drum contains steam bubbles

sloped, air pockets may form in the lines creating improper drum level measurement.

When a differential pressure transmitter is used to measure drum level and the instruments used are sensitive to density variation, density compensation techniques must be employed. A mass steam flow and water flow signal is required for two and three element control systems.

5. Boiler Feed Water Control

Some boilers utilize a reasonably steady load so only drum level control from single element drum level measurement is possible. Single element control is used on boilers during startup or low load regardless of capacity or rapid load swings. Single element control has often been unsatisfactory because some of the newer boiler designs have minimum water storage compared to the steaming rate of the boiler. A majority of the larger sized units and those subject to rapidly fluctuating loads require different methods of control. A two element system controlling the feed water control valve from the steam flow signal and resetting the drum level signal is able to handle some of the less difficult systems. Larger units with small storage capacity related to throughput, and units experiencing severe, rapid load swings, usually require three element controls, whereby water flow is matched with steam flow and reset from the drum level signal.

5.1 Single Element Feed Water Control

Single element drum level control measures drum level only. This is a simple feedback control loop.

The mass of the water flow and the steam flow must be regulated so mass water flow equals the mass steam flow to maintain drum level. The feed water control regulates the mass water flow to the boiler. The effects of the input control actions interact, since firing rate also affects steam temperature and feed water flow affects the steam pressure, which is the final arbiter of firing rate demand. The overall system must be applied and coordinated in a manner to minimize the effects of these interactions. The interactions can be greatly affected by the control system design. If the boiler operates under varying steam pressure, the calibration of the liquid level transmitter will also vary with steam density.

When a single element control system is implemented, the level transmitter (LT) sends a signal to the level controller (Figures 3 and 4). The process variable (input signal) to the controller is compared to the set point (SP). Single element control is the minimum feed water control system. When the system consists of single and two or three

element control, two controllers are required because the controller tuning is different.

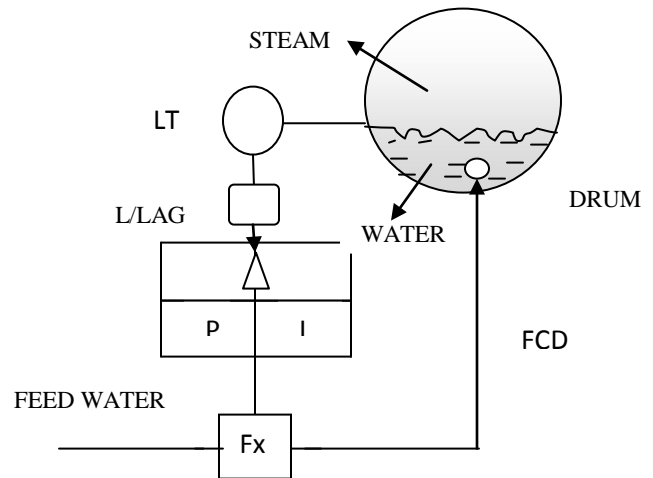

Figure-3 Single element control

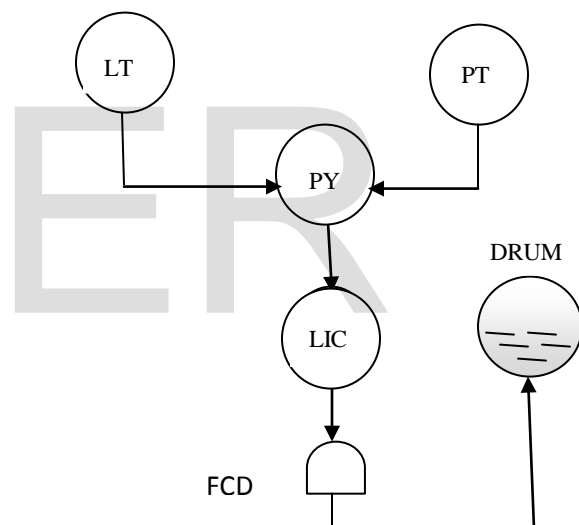

Figure-4 Single element feed water control

The output signal is modified and adjusts the final control device. The diagram for a P&ID would typically be in ISA symbols (Figure 4). The final control device can be a control valve, pump speed control, or a combination of both. For simplicity, redundant transmitters are not shown on the P&ID drawings.

5.2. Two element feed water control

The two element control scheme utilizes steam flow in addition to drum level. This is a simple feedback plus feed forward control system (Figure 5) with a secondary variable that has a predictable relationship

with the manipulated variable. The secondary variable, steam flow, causes the manipulated variable to change the primary variable. The steam flow adjusts the feed water control valve based on steam flow signal and the drum level controller signal. As the steam flow increases or decreases, the steam flow adjusts the output of the summer and directly sets the feed water final element.

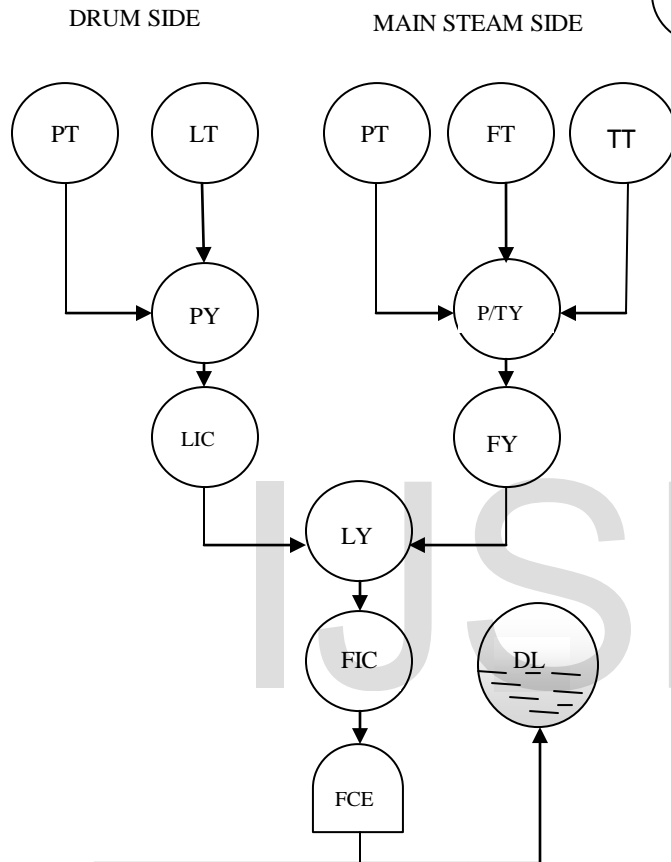

Figure-5 Two element feed water control

If the conditions are ideal, as in Figure 4, the feed water flow would be equal to steam flow, and the level in the drum would be maintained. If feed water pressure is not constant, as seen in Figure 5, the changes in pressure would affect feed water control.

5.3 Three element feed water control

Three element controls utilizes steam and water flow in addition to drum level (Figure 6). This is a simple feedback, feed forward, and cascade control loop. The steam flow adjusts the feed water control valve based on the steam flow signal and the drum level controller signal. As the steam flow increases or decreases, the steam flow adjusts the output of the summer and directly sets the feed water controller set

point. By adding feed water flow, the measured variable is the feedback to the controller, therefore measuring what is being controlled. Control is improved by adding mass flow compensation to drum level, steam flow, and water flow.

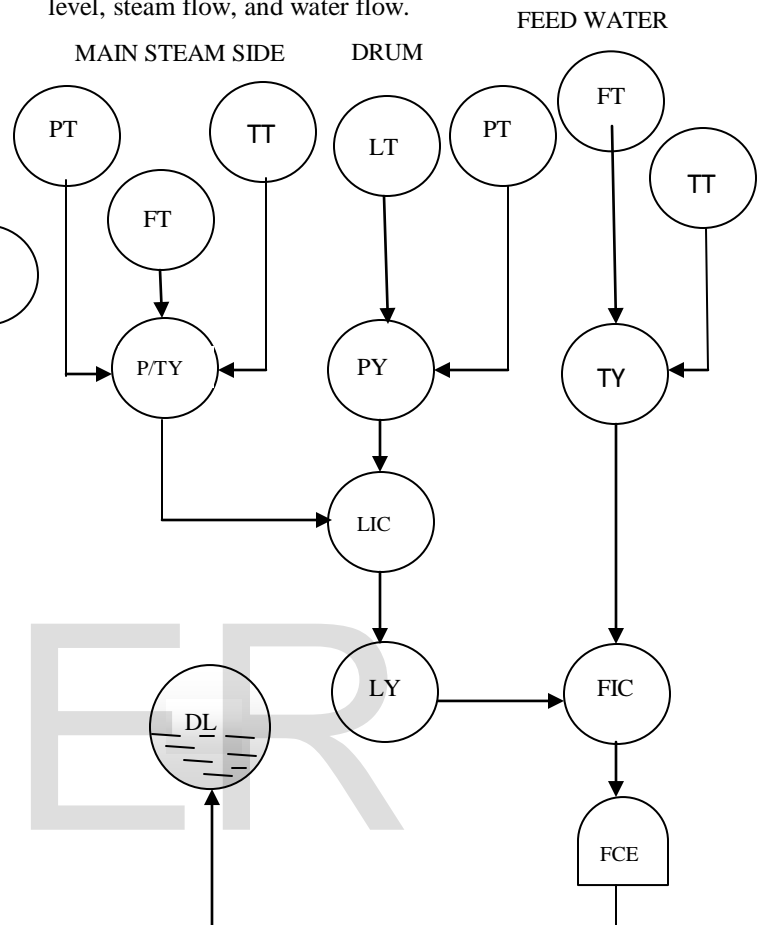

Figure-6 Three element feed water control

6. Control System Configure

The drum level controller is configured to be either a reverse- or direct-acting controller. This depends on the configuration of the final control device and the failsafe mode of the control valve. If the control valve fails closed, the controller is configured to be a reverse-acting controller. If the control valve fails open, the controller is configured to be a direct-acting controller. The final control element may be a control valve, speed control, or a combination of both. Speed control is used to reduce line pressure drop and is also used in combination with a control valve to establish greater turn down.

6.1 Drum Level Measurement

$$\Delta P = (r_a - r_w)g(H_0 + \Delta H) + (r_a - r_s)g(H - H_0 - \Delta H)$$

$$\Delta H = \frac{(r_a - r_s)H - \Delta P}{(r_s - r_w) - H_0}$$

$$\Delta H = \frac{[H * f_1(p) - \Delta P]}{f_2(p) - H_0}$$

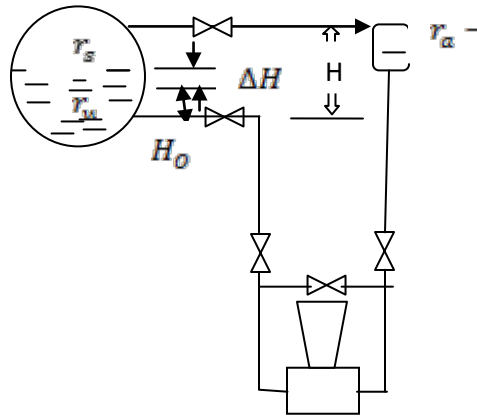

Figure-7 drum level measurement

- ΔH - Water Level of Steam Drum in mm
- H - Elevation of Reference Water Column in mm.
- H_0 - Zero Water Level, elevation between water sampling control centers to the center line of drum in mm
- r_a - Density of Water column in Reference Container in N/m³.
- r_s - Density of Saturated steam in Steam drum in N/m³.
- r_w - Density of Saturated water in Steam drums in N/m³.
- $f_1(p) = (r_a - r_s)$
- $f_2(p) = (r_w - r_s)$

Density of water in balance container is related to ambient temperature.

7. Summer

A summer occurs when two or more values come into an equation and the output equals the sum of the inputs in percent based on the K values. The functions are referred to as function blocks or algorithms. The summer equation is used although the equation is not functioning as a summer. The equations used will vary with the control systems specified, including the number of inputs. The equation below represents three inputs: a, b and c. Only two inputs are used in Figure 7. This is a

common type of equation that may have two or more inputs depending on the vendor algorithm/function block. A basic equation performing the same function should be available with most control systems.

$$K(a) + K(b) + K(c) \pm \text{Bias} = \text{output}$$

Considering two inputs to the summer, set both K values to 1. Set the bias to -50%. With the drum level controller in manual mode and the drum level at the desired set point, set the controller output to 50%.

The 50% output is offset by the -50% bias in the summer equation. Therefore, the steam flow signal input to the summer will equal the summer output. Considering a pound of steam equals a pound of water, the drum level would be maintained during all load changes. Even though swell and shrink may occur on load swing, the steam flow modifies the feed water rate.

8. Result

8.1 Normal condition

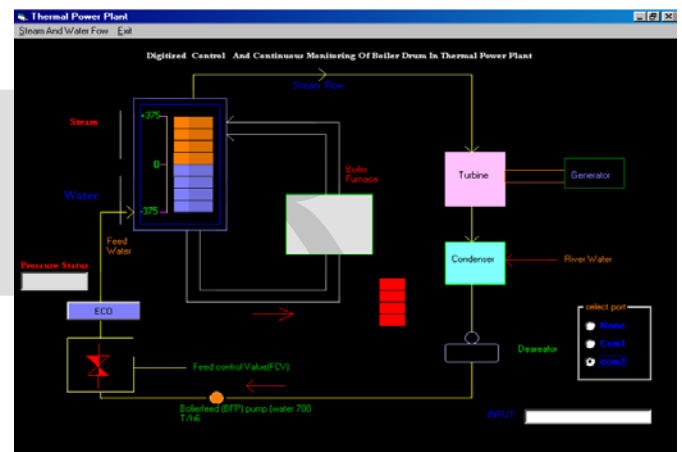

8.2 Parameter value changed depends on load variation (water level low)

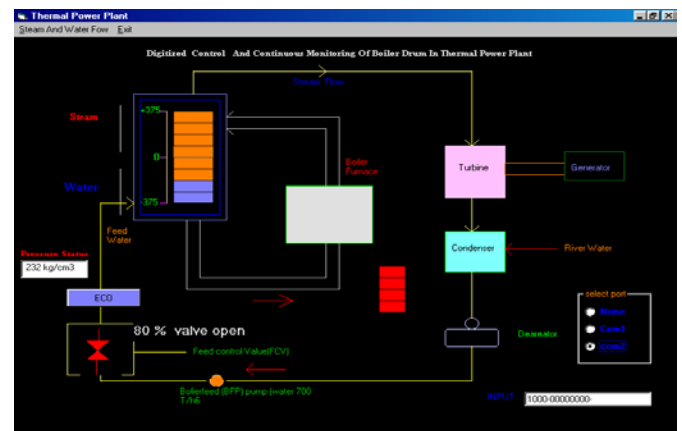

8.3 Parameter value changed depends on the load variation (water level high)

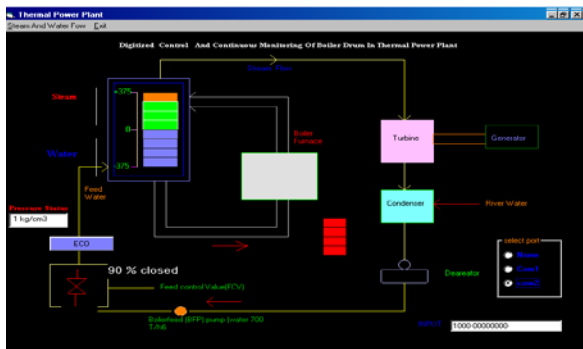

8.4 Trip condition

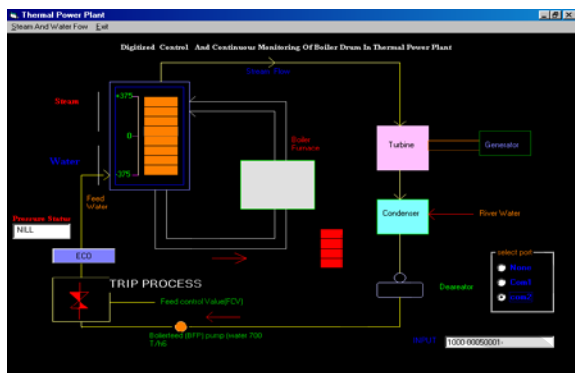

9. Conclusion

Embedded control with PC-based methodology is proposed in this paper to integrate machine level control and high level supervision properly for performance improvement of steam flow, water flow and water level process. The steam temperature control is greatly improved by PC based control for primary-secondary processes, with significantly reduced primary-secondary coupling. The above PC based control system is easy to implement without large modification to the original system. The PC base control system for the water level control has successfully replaced the human operator to gain automatic performance. The real industrial operation demonstrates that a better performance than traditional methods is archived for both steam temperature and water level process.

The embedded system technology incorporated provides a simplified processing mode helping lesser interference of the user. The multimedia output provided helps the user to interact better with the system. The signal and conditions can be effectively sensed without fails and can be taken for processing. The whole system can be integrated for the networking purpose where automatic controls of the

substation are carried with no manual intervention. Also the use of embedded system reduces the whole size of the control instruments and also increase the sensitivity of the system (detects the fault in very short time). In the existing system there is a drawback of time delay in the detection of fault. This drawback is eliminated here by use of embedded system technology.

12. Acknowledgement

I would like to sincerely thank to Mr. CHRISTOPHER, EXECUTIVE ENGINEER in C&I of Mettur thermal Power Station, Mettur Dam for his incessant inspiration, constructive crisis's, keen interest and warm encouragement throughout the project period and for his valuable guidance during the whole project and a non source of inspiration and support to all.

REFERENCES

- [1] M. Iacob, G.-D. Andreescu, *Drum-boiler control system employing shrink and swell effect remission in thermal power plants*, Proc. 2011 3rd International Congress on Ultra Modern Telecommunications and Control Systems and Workshops (ICUMT), Budapest, Hungary, ISSN: 2157-0221, ISBN: 978-1-4577-0682-0, pp. 1-8, Oct. 2011. *iee*
- [2] E.H. Gurban, G.-D. Andreescu, *SCADA element solutions using Ethernet and mobile phone network*, Proc. 2011 IEEE 9th Int. Symposium on Intelligent Systems and Informatics (SISY), Subotica, Serbia, ISBN: 978-1-4577-1975-2/11, pp. 303-308, Sep. 2011. *iee*.
- [3] M. Iacob, G.-D. Andreescu, N. Muntean, *SCADA system for a central heating and power plant*, (in book chapter 8: Process Control and Automation Applications), in *Instrument Engineers' Handbook Vol. 3: Process Software and Digital Networks*, 4th Edition, Eds.: B.G. Liptak, H. Eren, CRC Press, USA, ISBN: 978-1439817766, pp. 930-939, Aug. 2011.
- [4] C.A. Bejan, M. Iacob, G.-D. Andreescu, *SCADA automation system laboratory, elements and applications*, Proc. 7th Int. Symposium on Intelligent Systems and Informatics, 2009, SISY '09, Subotica, Serbia, ISBN: 978-1-4244-5348-1, pp. 181-186, Sep. 2009. *iee*